

TECNOTION[®]

THE LINEAR MOTOR COMPANY

Frameless torque motor series



QUALITY AND SERVICE DELIVERED WORLDWIDE

[TECNOTION]

Tecnotion is *the* global authority on direct drive motor technology. We are the world's only unbundled manufacturer of linear and torque motors. As a former part of Philips, we specialize solely in the development and production of linear and torque motors. Because of this, our expertise, customer service and product quality are unmatched.

We have a global presence, with production plants in the Netherlands and China and local representation around the world. This ensures short delivery times and high quality support, wherever you are located.

When you do business with Tecnotion, you have a team of highly skilled sales and application engineers at your disposal. They help you from your initial prototype all the way to the application of our products and beyond.

Whatever your needs, you can rely on Tecnotion as a solid, reliable partner.





[SALES SUPPORT]

At Tecnotion we understand that each application of our motors is a unique case with specific requirements and demands.

Our sales and application engineers have extensive experience with a wide range of application types and collaborate on a high level with our customers to make sure you get the solution that best fits your requirements.

Additionally our specialized simulation tool is available to help you find your way through our wide range of motors and analyze/test out different motor types within your application specifications.

[INNOVATION]

We have an in-house R&D department, which is continuously pushing the boundaries of technology and taking our products to the next level. This translates directly to our high level of understanding of manufacturing processes.

Apart from our “off-the-shelf” range of standard motors, we can also design and manufacture custom made motors for high profile projects or OEM applications that require a tailor-made solution.

All our custom motors are built to the same high standards that characterize our standard range of products.

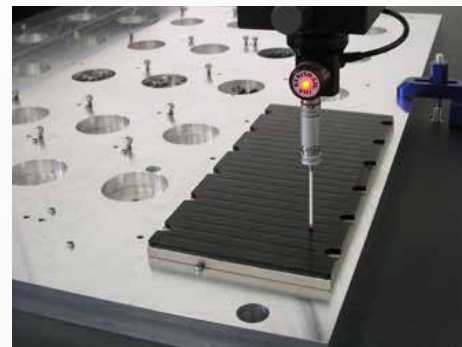

[MANUFACTURING]

Manufacturing of our standard range of motors takes place at our modern plant in China, where we are able to produce in high volume at very competitive rates.

At our competence centre and headquarters in the Netherlands we specialize in advanced technology. This is where we do our research and development and where custom motors are built with extreme accuracy in our special state of the art clean room environment.

Tecnotion is committed to excellence. Both of our plants are ISO 9001 certified and comply to the highest quality standards possible.

[GLOBAL LOGISTICS]

We always have our most popular products in stock in our warehouses in both the Netherlands and China.

Our logistics department can ship to you from both locations, making short delivery times possible across the globe, even when markets are ramping.



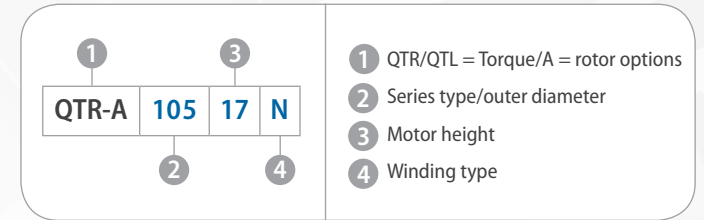

QTR-A 65 and 78 series

See page 13

The QTR-A 65 and 78 are the smallest motors from our torque range. The largest QTR-A 78-60 motor offers a ultimate torque of 10.85 Nm. Compact sizing and low voltage support makes the QTR 65 motor ideal for robotics applications. Small build-space and a large 29mm inner diameter make

the QTR 78 motor a favorite in semiconductor machinery. To provide maximum flexibility and integration the motor is equipped with flying leads instead of a power cable.

These motor series comes in two diameters: 65 and 78 mm and four heights: 17, 25, 34 and 60 mm.



QTR-A 105-133-160 series

See page 17

Our medium range motors are available with a range of options. Different winding types are available, optimizing back EMF. A digital Hall sensor can be used as a 'wake and shake' replacement, simplifying the startup of the QTR motor. The largest QTR-A 160-60 motor, excels with a 91.6 Nm ultimate torque.

Various applications such as in medical, testing equipment, and factory automation benefit from the large inner diameter and the high peak torque of the series.

These motor series comes in three diameters: 105, 133 and 160 mm and four heights: 17, 25, 34 and 60 mm.



QTL-A 210-230-290-310 series

See page 23

The QTL motor series are our largest torque motors up to date, yet very compact for the generated torque. The QTL is frameless as all our QTR motors and therefore it can be integrated directly into the machine structure, while the spacious open inner diameter enables wire and cable feed-through. The series are suitable

for a variety of markets including rotary indexing tables, printing machinery and materials handling. Available with (QTL 230 and 310) or without cooling ring (QTL 210 and 290).

The QTL-A motor series comes in four diameters (210, 230, 290 and 310 mm) and three heights (65, 85 and 105 mm).

Frameless torque motors









Torque motor power range



Ultimate torque



Continuous torque

 QTR-65 Series	0.64 - 5.47 Nm				
	0.29 - 2.31 Nm				
 QTR-78 Series		1.22 - 10.85 Nm			
	0.57 - 4.41 Nm				
 QTR-105 Series		2.9 - 28.4 Nm			
		1.4 - 12 Nm			
 QTR-133 Series		5.6 - 55.5 Nm			
		2.6 - 21.9 Nm			
 QTR-160 Series		9.3 - 91.6 Nm			
		4.1 - 36.3 Nm			
 QTL-210 Series			173 - 346 Nm		
			65 - 142 Nm		
 QTL-230 Series			173 - 346 Nm		
			67 - 147 Nm		
 QTL-290 Series			389 - 778 Nm		
			140 - 305 Nm		
 QTL-310 Series			389 - 778 Nm		
			151 - 331 Nm		
	0.2 Nm	1 Nm	10 Nm	100 Nm	1000 Nm

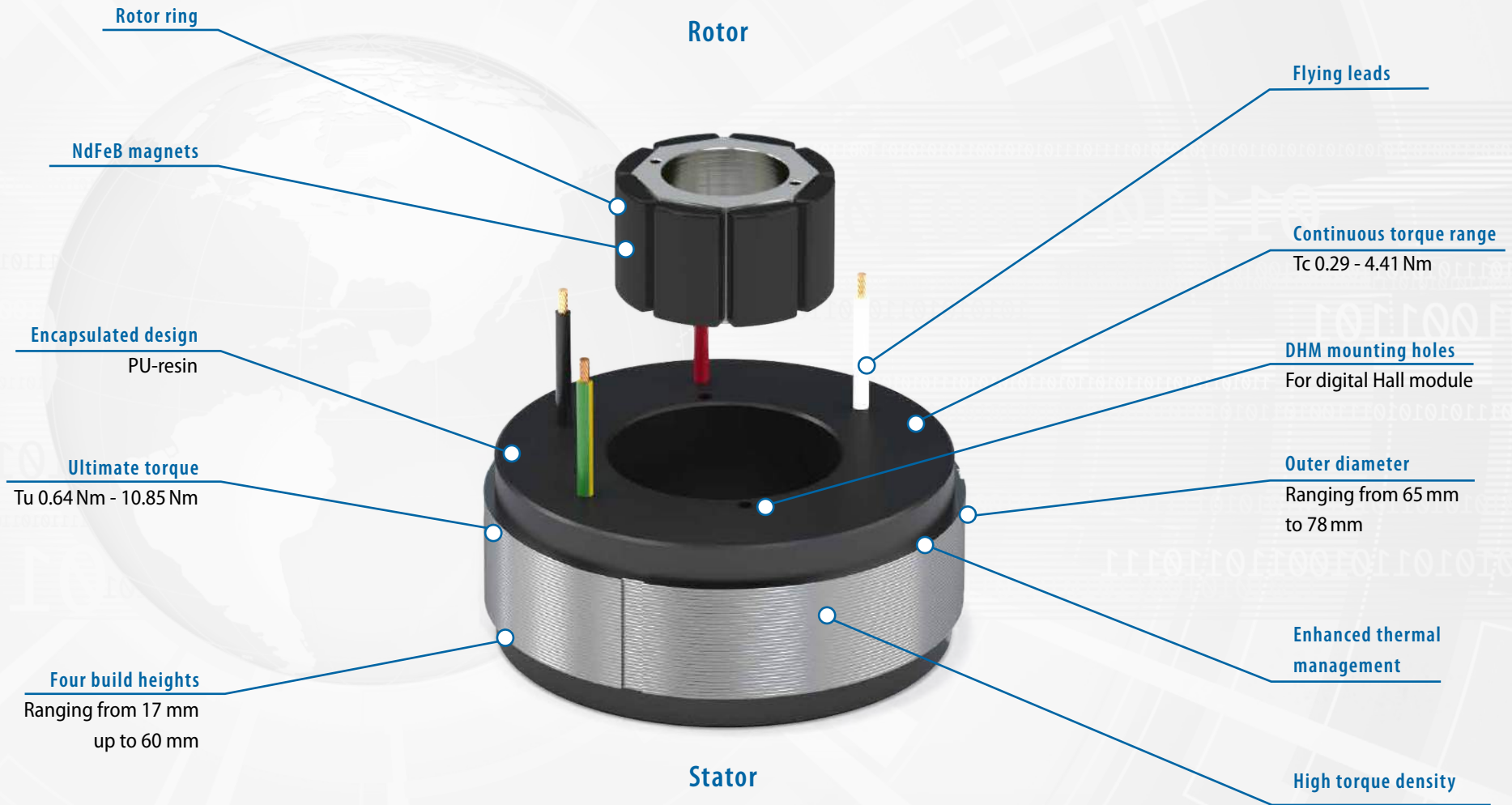

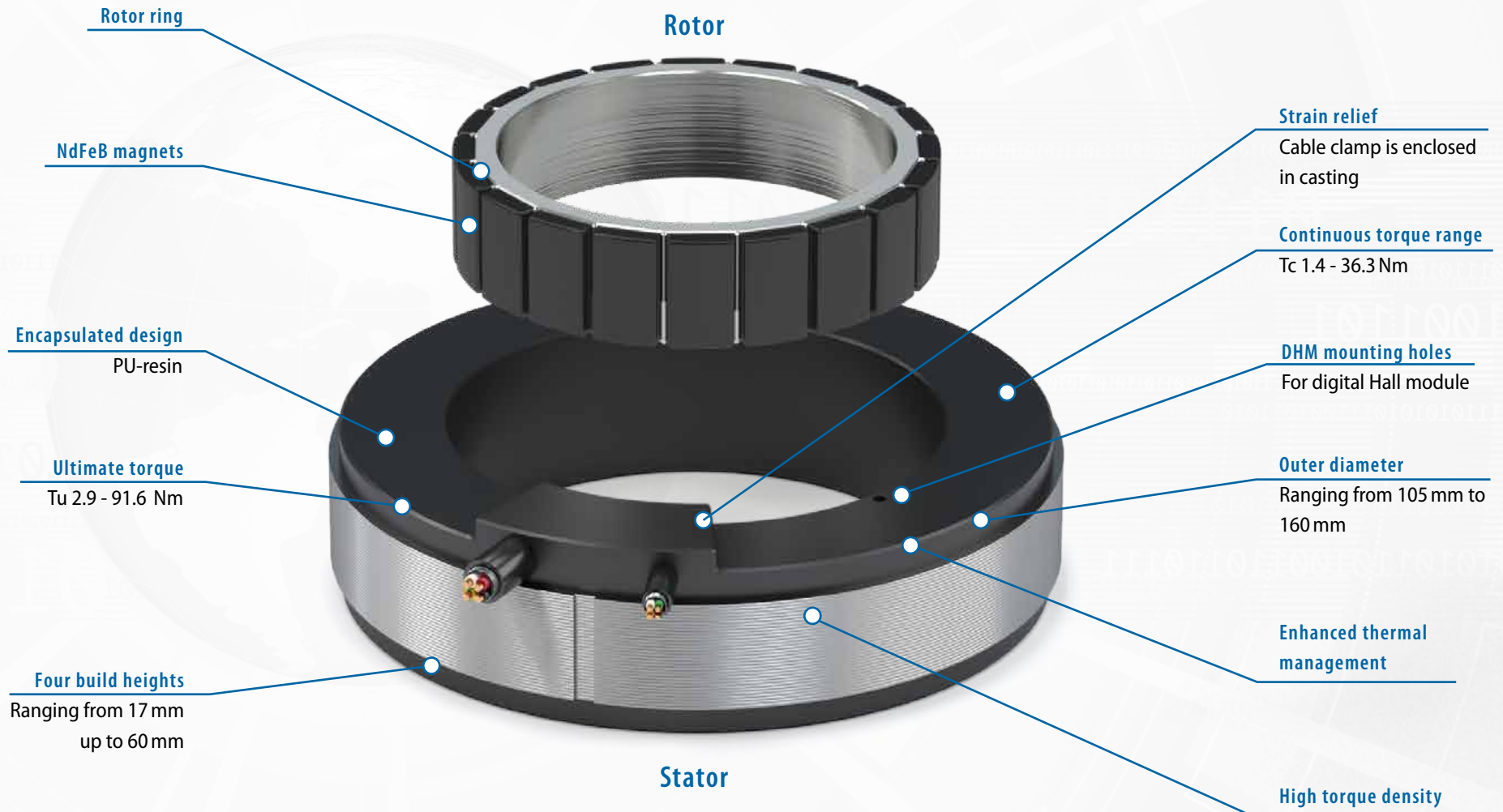

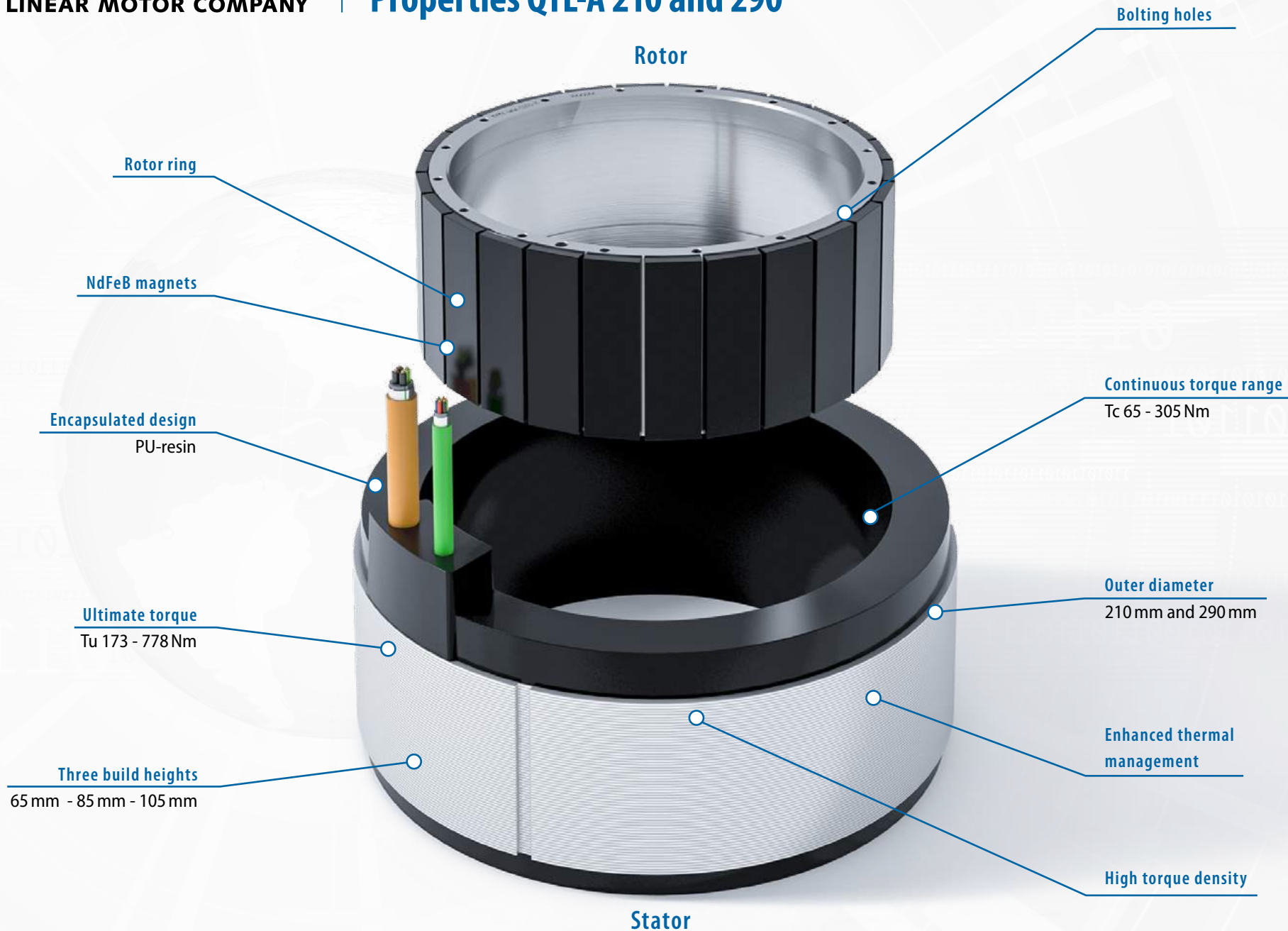

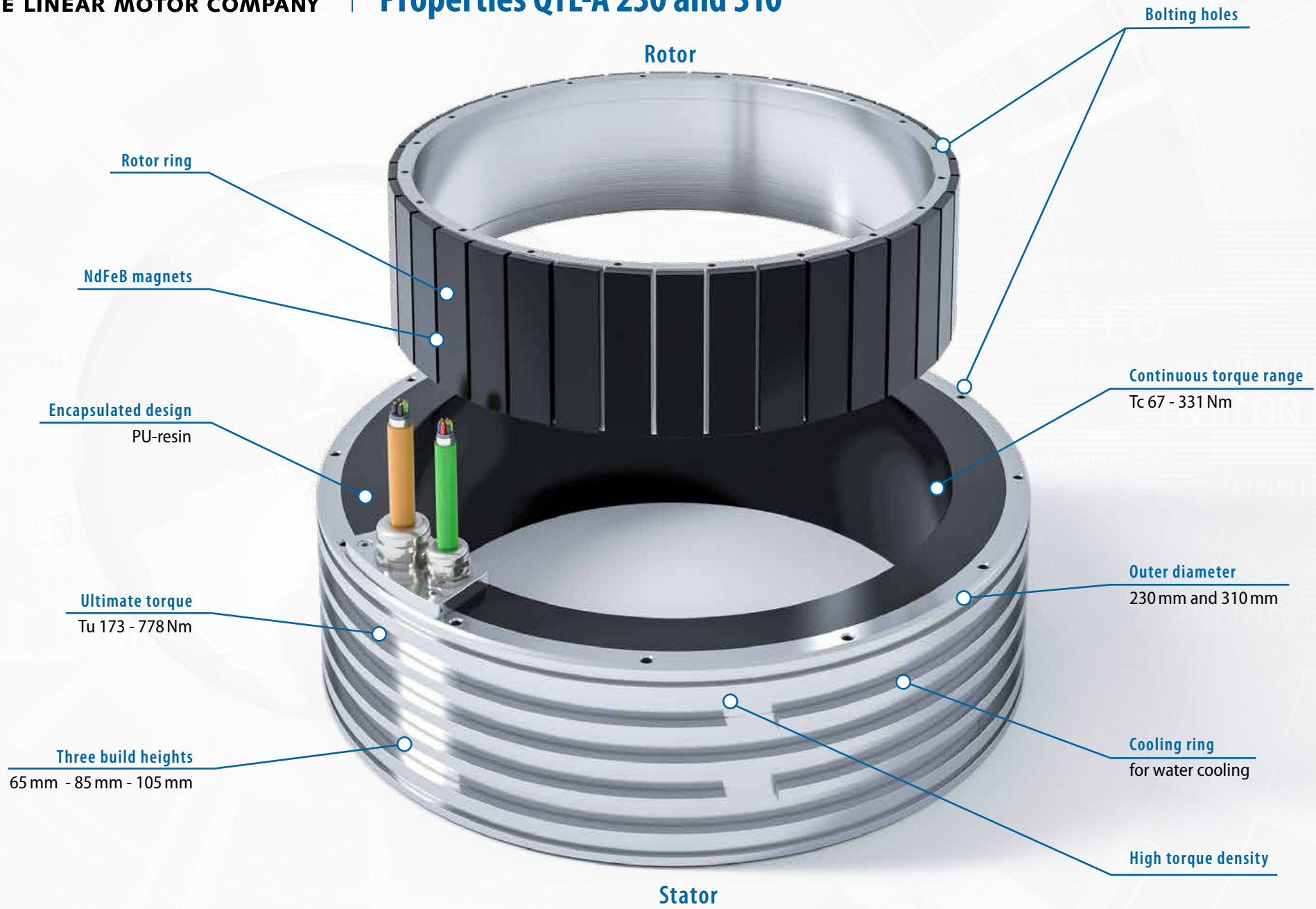

Features

Tecnotion's QTR torque motor performance advantages

The direct drive technology of brushless torque motors is a perfect way to enhance productivity, accuracy, and dynamic performance of applications. The technology lowers costs, makes designs slimmer, and reduce wear and tear. Torque motors eliminate the need for mechanical transmissions like gearboxes, belts and speed reducers. Between rotor and stator there is no contact, this means no mechanical wear.

Direct drive
Higher stiffness no backlash.

Ultra thin design
The lower build height allows to build a flatter axis, resulting in less tipping and settling time. Extraordinary flexibility in designing the motor into small spaces.

Tecnotion QTR has the highest torque density in the market
More torque in a smaller packing means lowering footprint.

Low thermal resistance
Allowing good heat transfer, achieving an extremely high continuous torque when using a decent size heatsink or active cooling.

Low cogging value, low total harmonic distortion THD
For smooth motion and position accuracy in your application.

Encapsulated design
No open coil wires which can be damaged or that need to be covered up for safety reasons.



Shielded cable with strain relief

No shielding EMC issues with loose wires. No risk to damage the motor by accidentally pulling the cable.

Low stator and rotor mass

Lower masses increase the dynamics and response of the system by lowering the inertia. It hands the opportunity to improve entire stage designs! And as a result, lowering an applications cost of ownership.

Large inner diameter

Allows easy integration of a large number of cables and hoses or allows large shaft fittings.

High voltage insulated, up to 300VDC/600VDC bus voltage

Enabling the use of a wide range of servo drives, and power supplies.

Good product repeatability

All motors have specifications with extremely little variation between them.

100% QC

All products are 100% mechanically and electrically tested.

Torque QTR-A digital Hall module

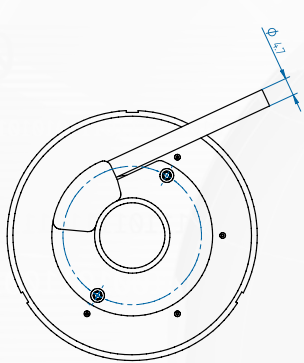

Digital Hall module mounted* on
QTR-A 65 series

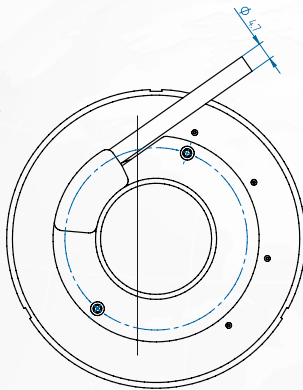

Digital Hall module mounted* on
QTR-A 78 series

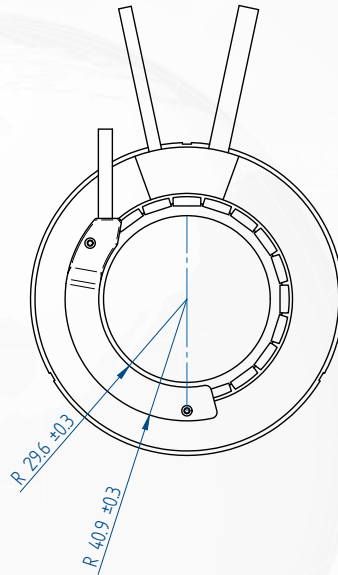

Digital Hall module mounted* on
QTR-A 105 series

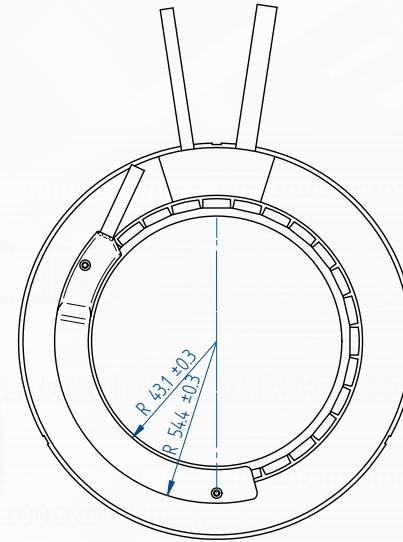

Digital Hall module mounted* on
QTR-A 133 series

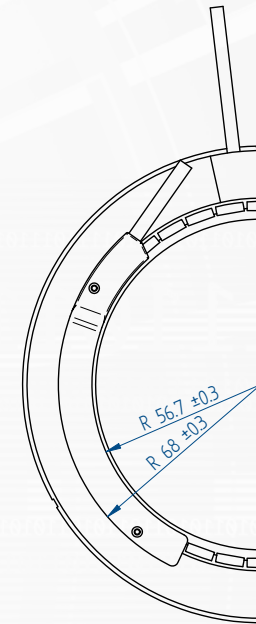

Digital Hall module mounted* on
QTR-A 160 series



Specifications

Input voltage:	5V...15Vdc
Output voltage:	3 phase TTL, max 2.5mA, 5Vdc AquadB TTL, max 2.5mA, 5Vdc

Tecnotion QTR motors can be equipped with a Tecnotion QTR digital Hall module. The module covers a small portion of the motor and measures just a little over 3 mm in thickness for the largest part.

When a QTR stator is not powered the Tecnotion QTR digital Hall module can be used to determine the electrical position of the rotor. It is a 'wake and shake' replacement, simplifying the startup of the QTR motor.

Digital Hall sensors are available for the QTR-A 65, 78, 105, 133 and 160 series.



* Mounting instructions and tolerances can be found in the torque installation manual. Manuals and 3D CAD files can be downloaded from our website.

Mounting instructions and tolerances can be found in the torque installation manual. Manuals and 3D CAD files can be downloaded from our website.

STATOR

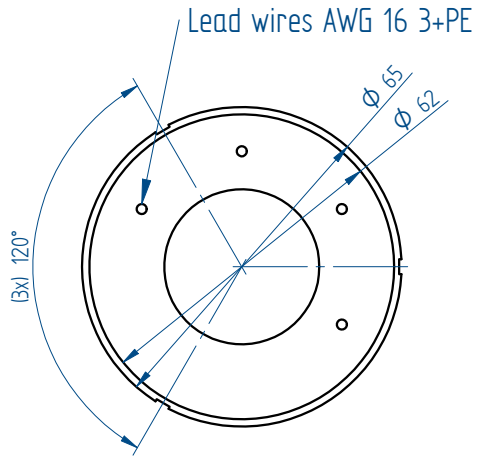

QTR-A 65-17

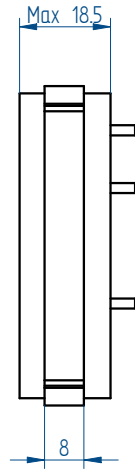

QTR-A 65-25

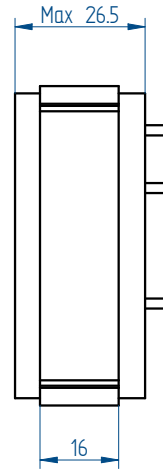

QTR-A 65-34

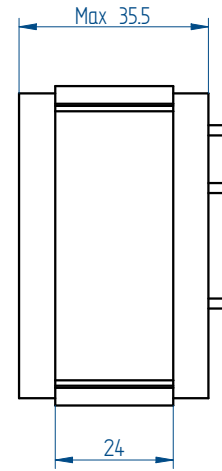

QTR-A 65-60

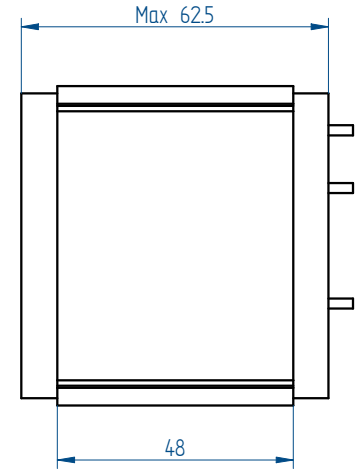

ROTOR

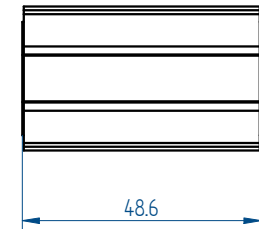
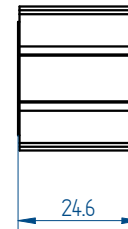
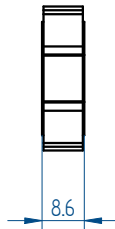
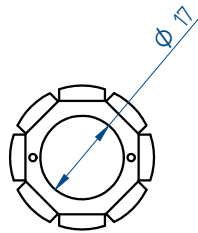

* All sizes are in mm

©2019 Tecnotion BV - All rights reserved - The contents of this document are subject to change without prior notice.

	Parameter	Remarks	Symbol	Unit	QTR-A 65-17	QTR-A 65-25	QTR-A 65-34	QTR-A 65-60
Performance	Winding type				N	N	Y	Y
	Motortype max. voltage ph-ph	3-phase synchronous		$V_{acrms} (V_{dc})$	420 (600)			
	Ultimate torque @ 20°C/s increase	magnet @ 25°C	T_u	Nm	0.64	1.31	2.25	5.47
	Peak torque @ 6°C/s increase	magnet @ 25°C	T_p	Nm	0.42	0.85	1.43	3.82
	Continuous torque	coil @ 100°C	T_c	Nm	0.29	0.66	1.08	2.31
	Maximum speed ⁽³⁾ @ 48 Volt	@ Tc	n_{max}	rpm	5735	2673	3456	910
	Maximum speed @ max. voltage	@ Tc	n_{max}	rpm	28000	28000	28000	16960
	Motor torque constant	up to Ic	K_t	Nm/A _{rms}	0.060	0.118	0.098	0.267
	Motor constant	coils @ 25°C	K_m	(Nm) ² /W	0.0021	0.0059	0.0111	0.0321
	Electrical	Ultimate current	magnet @ 25°C	I_u	A _{rms}	13.84	13.84	27.98
Peak current		magnet @ 25°C	I_p	A _{rms}	7.58	7.58	15.32	15.05
Maximum continuous current ⁽¹⁾		coils @ 100°C	I_c	A _{rms}	4.86	5.61	11.07	8.65
Back EMF phase-phase _{peak}			K_e	V/krpm	5.1	10.1	8.4	22.8
Back EMF phase-phase _{RMS}			K_e	V/krpm	3.6	7.2	5.9	16.1
Coil resistance per phase		coils @ 25°C ex. cable	R	Ω	0.575	0.799	0.287	0.741
Coil induction per phase		$l < 0.6 l_p$	L	mH	0.86	1.62	0.69	2.10
Electrical time constant		coils @ 25°C	τ_e	ms	1.5	2.0	2.4	2.8
Poles			N_{mgn}	nr	8	8	8	8
Thermal		Continuous power loss	coils @ 100°C	P_c	W	53	99	138
	Thermal resistance ⁽²⁾	coils to mount. sfc.	R_{th}	°C/W	1.50	0.81	0.58	0.37
	Thermal time constant	up to 63% max. coiltemp.	τ_{th}	s	21	16	16	38
	Temperature cut-off / sensor				No temperature sensor			
Mechanical	Stator OD		OD _s	mm	65			
	Rotor ID		ID _R	mm	17			
	Motor height		H _{motor}	mm	18	26	35	62
	Lamination stack height		H _{arm}	mm	8	16	24	48
	Rotor inertia		J _R	kg*m ²	3.8E-06	7.5E-06	1.1E-05	2.3E-05
	Stator mass	excluding cables	M _s	g	149	248	361	717
	Rotor mass		M _R	g	27	54	80	160
	Total mass	excluding cables	M _T	g	176	302	441	877
	Cable mass	all cables	m	g	36			
Cable type (power)	length 0.5 m	d	mm (AWG)	2.06 (16)				

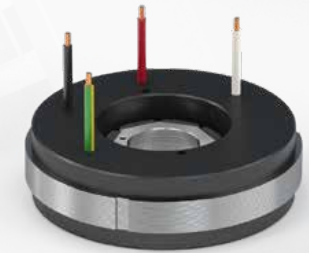

QTR-A 65 Stator and rotor shown with a height of 17 mm

1. These values are only applicable when the mounting surface is at 20°C and the motor is driven at maximum continuous current. If these values differ in your application, please check our simulation tool or manual.
2. Rth based on radial mounting of stator lamination stack.
3. MAXIMUM allowable speed for QTR-A 65 series motors is 28.000 rpm. If you plan a high speed application, please contact Tecnotion.

All specifications ±0%

Mounting instructions and tolerances can be found in the torque installation manual. Manuals and 3D CAD files can be downloaded from our website.

STATOR

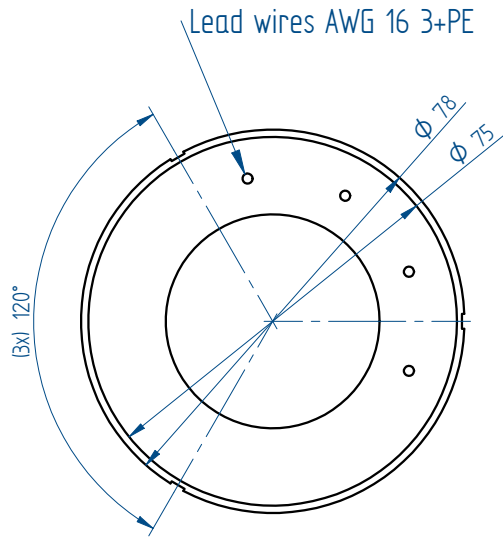

QTR-A 78-17

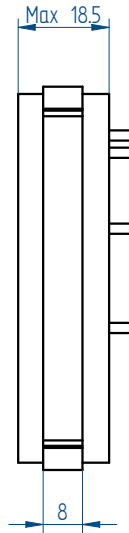

QTR-A 78-25

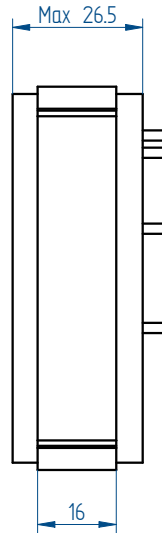

QTR-A 78-34

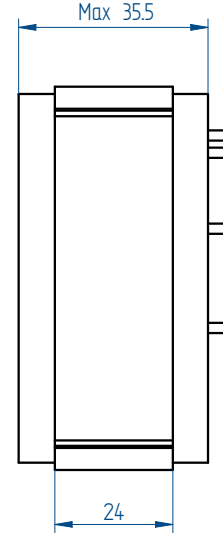

QTR-A 78-60

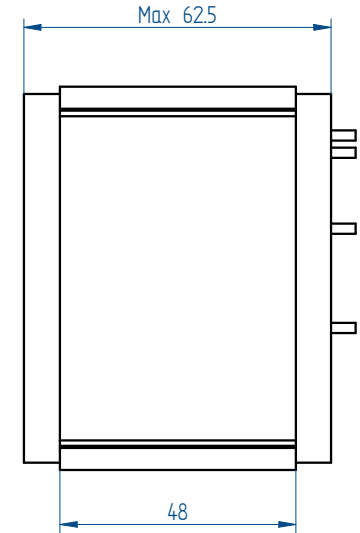

ROTOR

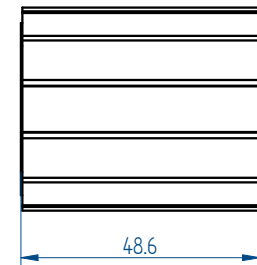
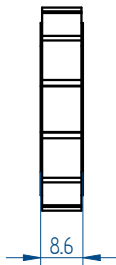
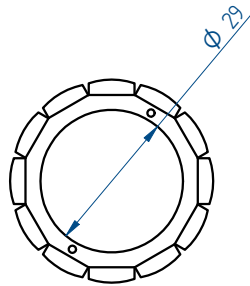

* All sizes are in mm

©2019 Tecnotion BV - All rights reserved - The contents of this document are subject to change without prior notice.

	Parameter	Remarks	Symbol	Unit	QTR-A 78-17	QTR-A 78-25	QTR-A 78-34	QTR-A 78-60
Performance	Winding type				N	Y	Y	Y
	Motortype max. voltage ph-ph	3-phase synchronous		$V_{acrms} (V_{dc})$	420 (600)			
	Ultimate torque @ 20°C/s increase	magnet @ 25°C	T_u	Nm	1.22	2.93	4.54	10.85
	Peak torque @ 6°C/s increase	magnet @ 25°C	T_p	Nm	0.84	1.90	2.88	7.57
	Continuous torque	coil @ 100°C	T_c	Nm	0.57	1.38	2.19	4.41
	Maximum speed ⁽³⁾ @ 48 Volt	@ Tc @ 48 Vdc	n_{max}	rpm	2657	2360	1463	324
	Maximum speed @ max. voltage	@ Tc	n_{max}	rpm	23000	23000	23000	8147
	Motor torque constant	up to Ic	K_t	Nm/A _{rms}	0.117	0.131	0.198	0.530
	Motor constant	coils @ 25°C	K_m	(Nm) ² /W	0.0053	0.0166	0.0304	0.0842
	Electrical	Ultimate current	magnet @ 25°C	I_u	A _{rms}	13.84	27.98	27.98
Peak current		magnet @ 25°C	I_p	A _{rms}	7.58	15.32	15.32	15.05
Maximum continuous current		coils @ 100°C	I_c	A _{rms}	4.89	10.56	11.08	8.33
Back EMF phase-phase _{peak}			K_e	V/krpm	10.0	11.2	16.9	45.3
Back EMF phase-phase _{RMS}			K_e	V/krpm	7.1	7.9	12.0	32.0
Coil resistance per phase		coils @ 25°C ex. cable	R	Ω	0.857	0.342	0.430	1.111
Coil induction per phase		l < 0.6 lp	L	mH	1.35	0.76	1.04	3.4
Electrical time constant		coils @ 25°C	τ_e	ms	1.6	2.2	2.4	3.1
Poles			N_{mgn}	nr	12	12	12	12
Thermal		Continuous power loss	coils @ 100°C	P_c	W	80	150	207
	Thermal resistance ⁽²⁾	coils to mount. sfc.	R_{th}	°C/W	0.99	0.53	0.39	0.26
	Thermal time constant	up to 63% max. coiltemp.	τ_{th}	s	20	16	16	41
	Temperature cut-off / sensor				No temperature sensor			
Mechanical	Stator OD		OD _S	mm	78			
	Rotor ID		ID _R	mm	29			
	Motor height		H _{motor}	mm	18	26	35	62
	Lamination stack height		H _{arm}	mm	8	16	24	48
	Rotor inertia		J _R	kg*m ²	1.3E-05	2.5E-05	3.8E-05	7.6E-05
	Stator mass	excluding cables	M _S	g	208	353	501	1003
	Rotor mass		M _R	g	42	84	126	243
	Total mass	excluding cables	M _T	g	250	437	627	1246
	Cable mass	all cables	m	g	36			
Cable type (power)	length 0.5 m	d	mm (AWG)	2.06 (16)				



QTR-A 78 Stator and rotor shown with a height of 17 mm

1. These values are only applicable when the mounting surface is at 20°C and the motor is driven at maximum continuous current. If these values differ in your application, please check our simulation tool or manual.
2. R_{th} based on radial mounting of stator lamination stack.
3. MAXIMUM allowable speed for QTR-A 78 series motors is 23.000 rpm. If you plan a high speed application, please contact Tecnotion.

All specifications ±0%

Mounting instructions and tolerances can be found in the Torque installation manual. Manuals and 3D CAD files can be downloaded from our website.

STATOR

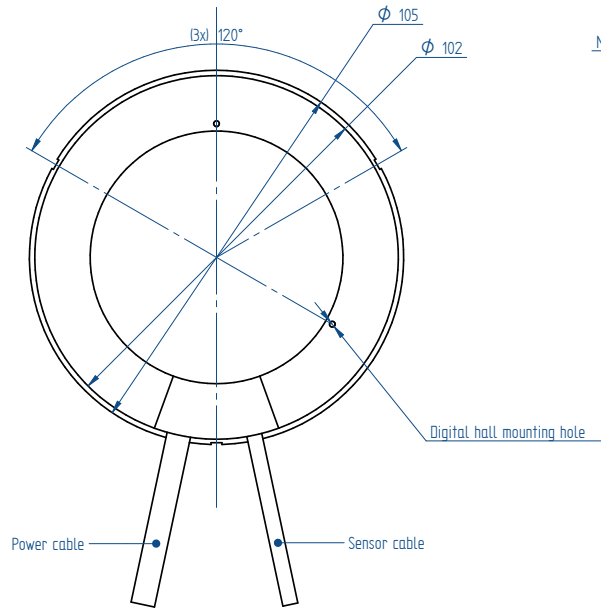

QTR-A 105-17

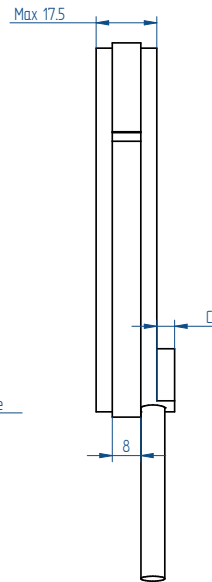

QTR-A 105-25

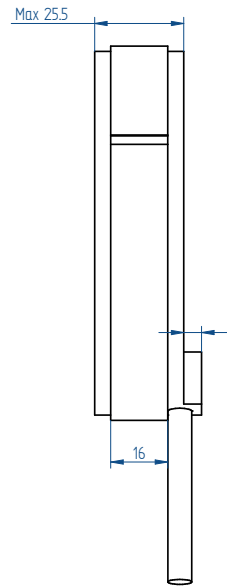

QTR-A 105-34

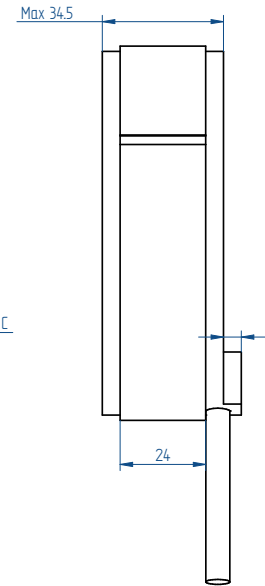

QTR-A 105-60

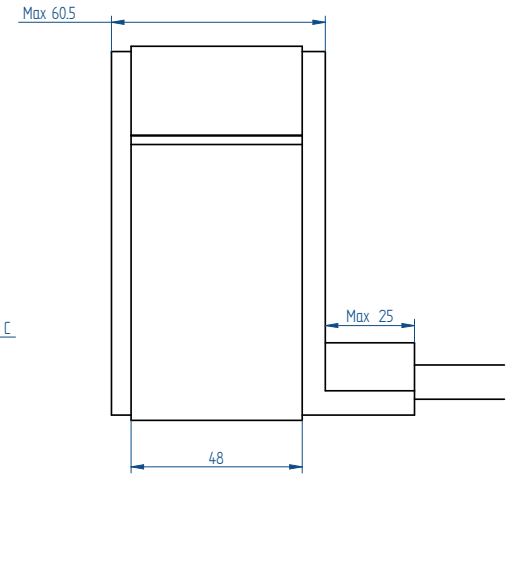

ROTOR

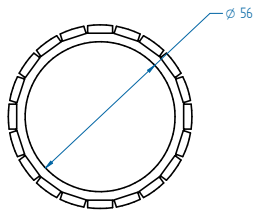

* All sizes are in mm

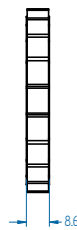

winding	C (mm)
N	3.5
Y+Z	5.5

©2019 Tecnotion BV - All rights reserved - The contents of this document are subject to change without prior notice.

Parameter	Remarks	Symbol	Unit	QTR-A-105-17			QTR-A-105-25			QTR-A-105-34			QTR-A-105-60
Winding type				N	Y	Z	N	Y	Z	N	Y	Z	N
Motor type max. voltage ph-ph	3-phase synchronous		$V_{acrms} (V_{dL})$	230 (300)									420 (600)
Ultimate torque @ 20°C/s increase	magnet @ 25°C	T_u	Nm	2.9	3.3	3.3	6.1	7.5	6.9	10.6	11.3	10.4	28.4
Peak torque @ 6°C/s increase	magnet @ 25°C	T_p	Nm	1.9	2.2	2.2	3.9	4.4	4.4	6.7	6.6	6.6	18.1
Continuous torque	coil @ 100°C	T_c	Nm	1.4	1.4	1.4	3.2	3.3	3.3	5.4	5.2	5.2	12.0
Maximum speed ⁽³⁾ @ 48 Volt	@ T_c	n_{max}	rpm	784	1761	3300	240	783	1623	0	444	1028	0
Maximum speed @ max. voltage	@ T_c	n_{max}	rpm	6890	12286	16500	3625	6534	11399	1928	4439	7833	1455
Motor torque constant	up to I_c	K_t	Nm/A _{rms}	0.30	0.17	0.10	0.60	0.33	0.19	1.07	0.50	0.29	2.86
Motor constant	coils @ 25°C	K_m	(Nm) ² /W	0.021	0.022	0.022	0.061	0.065	0.065	0.127	0.115	0.120	0.40
Ultimate current	magnet @ 25°C	I_u	A _{rms}	13.8	28.2	48.8	13.8	28.2	48.8	13.3	28.2	48.8	13.5
Peak current	magnet @ 25°C	I_p	A _{rms}	7.6	15.4	26.7	7.6	15.4	26.7	7.3	15.4	26.7	7.37
Maximum continuous current ⁽¹⁾	coils @ 100°C	I_c	A _{rms}	4.6	8.5	14.7	5.3	9.8	17.0	5.1	10.3	17.9	4.2
Back EMF phase-phase _{peak}		K_e	V/krpm	25	14	8	51	28	16	92	43	25	244
Back EMF phase-phase _{RMS}		K_e	V/krpm	18	10	6	36	20	12	65	30	17	173
Coil resistance per phase	coils @ 25°C ex. cable	R	Ω	1.38	0.43	0.14	1.93	0.57	0.19	3.02	0.74	0.24	6.84
Coil inductance per phase	$l < 0.6 l_p$	L	mH	2.58	0.83	0.28	4.05	1.29	0.43	7.93	1.75	0.59	25.3
Electrical time constant	coils @ 25°C	τ_e	ms	1.9	2.0	1.9	2.1	2.3	2.2	2.6	2.4	2.4	3.7
Poles		N_{mgn}	nr	20	20	20	20	20	20	20	20	20	20
Continuous power loss	coils @ 100°C	P_c	W	115	115	115	214	214	214	300	300	300	469
Thermal resistance ⁽²⁾	coils to mount. sfc.	R_{th}	°C/W	0.65	0.65	0.65	0.35	0.35	0.35	0.25	0.25	0.25	0.16
Thermal time constant	up to 63% max. coiltemp.	τ_{th}	s	21	25	25	16	18	18	17	17	17	25
Temperature cut-off / sensor				PTC 1kΩ / KTY83-122									
Stator OD		OD_s	mm	105									
Rotor ID		ID_R	mm	56									
Motor height		H_{motor}	mm	17			25			34			60
Lamination stack height		H_{arm}	mm	8			16			24			48
Rotor inertia		J_R	kg*m ²	8.0E-05			1.5E-04			2.2E-04			4.3E-04
Stator mass	excluding cables	M_s	g	299			472			746			1476
Rotor mass		M_R	g	79			146			218			433
Total mass	excluding cables	M_T	g	378			618			964			1909
Cable mass	all cables	m	g	63	90	90	63	90	90	63	90	90	95
Cable type (power)	length 0.5 m	d	mm (AWG)	6.5 (20)	6.7 (14)	6.7 (14)	6.5 (20)	6.7 (14)	6.7 (14)	6.5 (20)	6.7 (14)	6.7 (14)	9.6 (18)
Cable type (sensor)	length 0.5 m	d	mm (AWG)	4.3 (26)									



QTR-A-105 Stator and rotor shown with a height of 17 mm

1. These values are only applicable when the mounting surface is at 20°C and the motor is driven at maximum continuous current. If these values differ in your application, please check our simulation tool or manual.
2. R_{th} based on radial mounting of stator lamination stack.
3. MAXIMUM allowable speed for QTR-A 105 series motors is 16.500 rpm. If you plan a high speed application, please contact Tecnotion.

All specifications ±10%

Mounting instructions and tolerances can be found in the torque installation manual. Manuals and 3D CAD files can be downloaded from our website.

STATOR

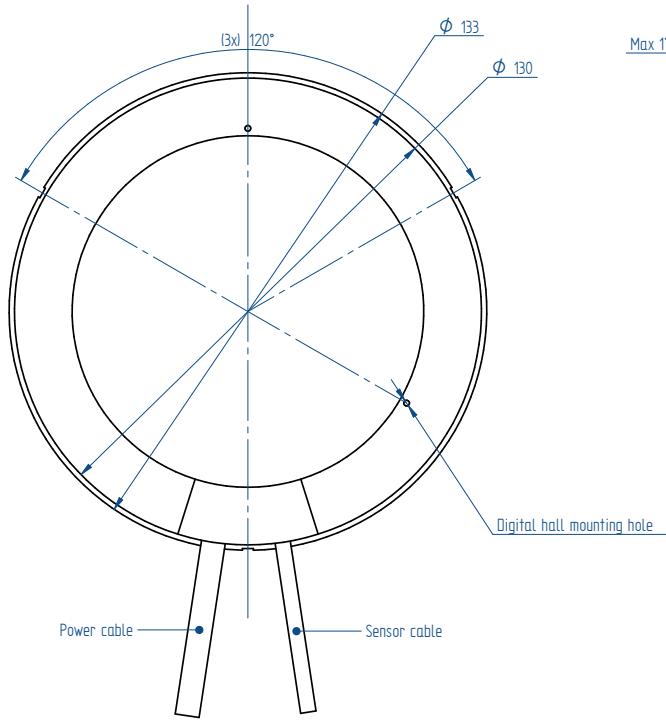

ROTOR

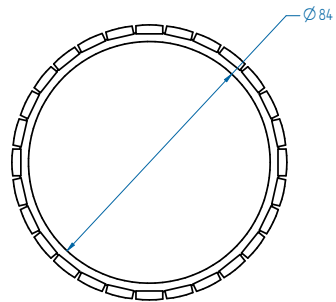

* All sizes are in mm

QTR-A 133-17

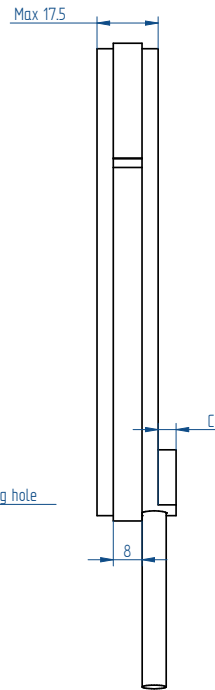

QTR-A 133-25

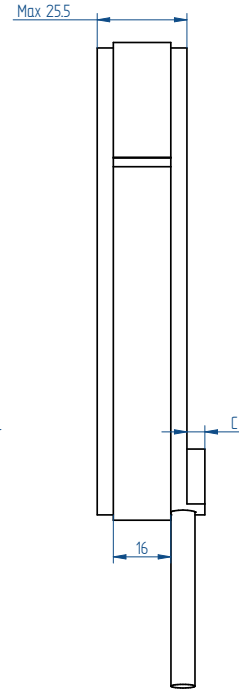

QTR-A 133-34

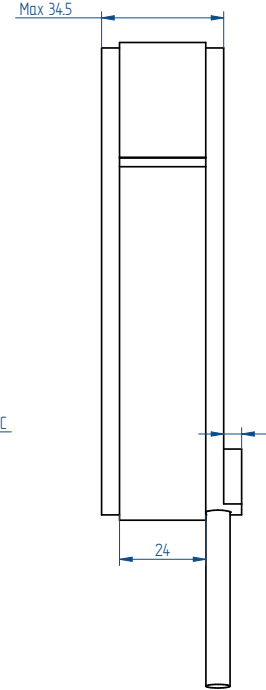

QTR-A 133-60

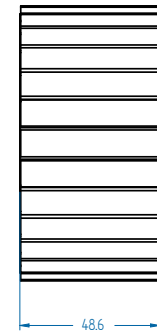
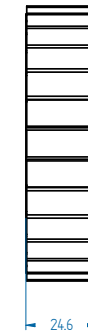
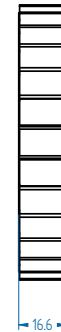
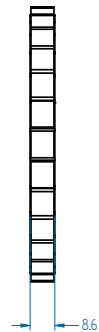
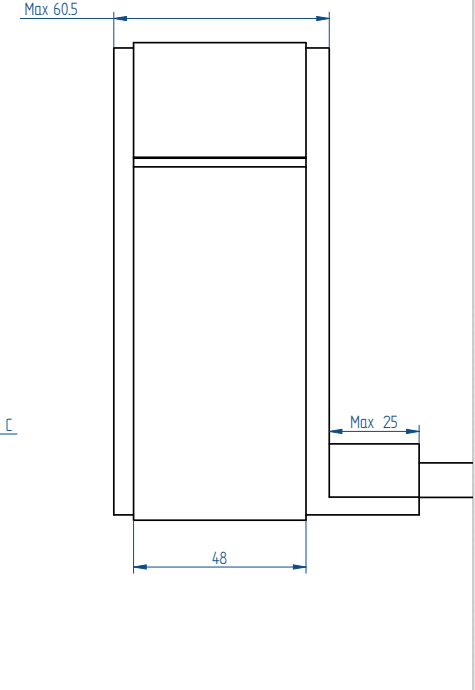

winding	C (mm)
N	3.5
Y+Z	5.5

©2019 Tecnotion BV - All rights reserved - The contents of this document are subject to change without prior notice.

Parameter	Remarks	Symbol	Unit	QTR-A-133-17			QTR-A-133-25			QTR-A-133-34		QTR-A-133-60	
Winding type				N	Y	Z	N	Y	Z	N	Z	N	
Motor type max. voltage ph-ph	3-phase synchronous		$V_{acrms} (V_{dc})$	230 (300)									420 (600)
Ultimate torque @ 20°C/s increase	magnet @ 25°C	T_u	Nm	5.6	6.4	6.4	11.9	13.5	13.5	20.6	20.3	55.5	
Peak torque @ 6°C/s increase	magnet @ 25°C	T_p	Nm	3.8	4.3	4.3	7.5	8.6	8.6	13.1	12.9	35.3	
Continuous torque	coil @ 100°C	T_c	Nm	2.6	2.6	2.6	5.9	6.0	6.0	10.0	9.5	21.9	
Maximum speed ⁽³⁾ @ 48 Volt	@ T_c	n_{max}	rpm	317	839	1641	33	345	788	0	478	0	
Maximum speed @ max. voltage	@ T_c	n_{max}	rpm	3514	6340	10807	1825	3389	5930	946	4040	724	
Motor torque constant	up to I_c	K_t	Nm/A _{rms}	0.58	0.33	0.19	1.16	0.65	0.38	2.09	0.56	5.57	
Motor constant	coils @ 25°C	K_m	(Nm) ² /W	0.058	0.061	0.061	0.167	0.177	0.180	0.344	0.310	1.08	
Ultimate current	magnet @ 25°C	I_u	A _{rms}	13.8	28.2	48.8	13.8	28.2	48.8	13.3	48.8	13.5	
Peak current	magnet @ 25°C	I_p	A _{rms}	7.56	15.40	26.70	7.56	15.40	26.70	7.31	26.70	7.37	
Maximum continuous current ⁽¹⁾	coils @ 100°C	I_c	A _{rms}	4.43	8.10	14.00	5.05	9.30	16.10	4.77	16.90	3.93	
Back EMF phase-phase _{peak}		K_e	V/krpm	50	28	16	99	56	32	179	48	476	
Back EMF phase-phase _{rms}		K_e	V/krpm	35	20	11	70	39	23	126	34	337	
Coil resistance per phase	coils @ 25°C ex. cable	R	Ω	1.93	0.58	0.20	2.70	0.80	0.27	4.23	0.34	9.58	
Coil inductance per phase	$l < 0.6 l_p$	L	mH	3.74	1.20	0.40	5.87	1.87	0.62	11.50	0.85	36.6	
Electrical time constant	coils @ 25°C	τ_e	ms	1.9	2.1	2.0	2.2	2.4	2.3	2.7	2.5	3.8	
Poles		N_{mgn}	nr	28	28	28	28	28	28	28	28	28	
Continuous power loss	coils @ 100°C	P_c	W	147	147	147	268	268	268	375	375	577	
Thermal resistance ⁽²⁾	coils to mount. sfc.	R_{th}	°C/W	0.51	0.51	0.51	0.28	0.28	0.28	0.20	0.20	0.13	
Thermal time constant	up to 63% max. coiltemp.	τ_{th}	s	23	27	27	18	21	21	19	19	29	
Temperature cut-off / sensor				PTC 1kΩ / KTY83-122									
Stator OD		OD _s	mm	133									
Rotor ID		ID _r	mm	84									
Motor height		H _{motor}	mm	17			25			34		60	
Lamination stack height		H _{arm}	mm	8			16			24		48	
Rotor inertia		J _r	kg*m ²	2.1E-04			4.2E-04			6.2E-04		1.2E-03	
Stator mass	excluding cables	M _s	g	414			717			1037		2090	
Rotor mass		M _r	g	106			208			309		613	
Total mass	excluding cables	M _t	g	520			925			1346		2703	
Cable mass	all cables	m	g	63	90	90	63	90	90	63	90	95	
Cable type (power)	length 0.5 m	d	mm (AWG)	6.5 (20)	6.7 (14)	6.7 (14)	6.5 (20)	6.7 (14)	6.7 (14)	6.5 (20)	6.7 (14)	9.6 (18)	
Cable type (sensor)	length 0.5 m	d	mm (AWG)	4.3 (26)									



QTR-A-133 Stator and rotor shown with a height of 17 mm

- All specifications ±10%
- These values are only applicable when the mounting surface is at 20°C and the motor is driven at maximum continuous current. If these values differ in your application, please check our simulation tool or manual.
 - R_{th} based on radial mounting of stator lamination stack.
 - MAXIMUM allowable speed for QTR-A 133 series motors is 14,000 rpm. If you plan a high speed application, please contact Tecnotion.

Mounting instructions and tolerances can be found in the torque installation manual. Manuals and 3D CAD files can be downloaded from our website.

STATOR

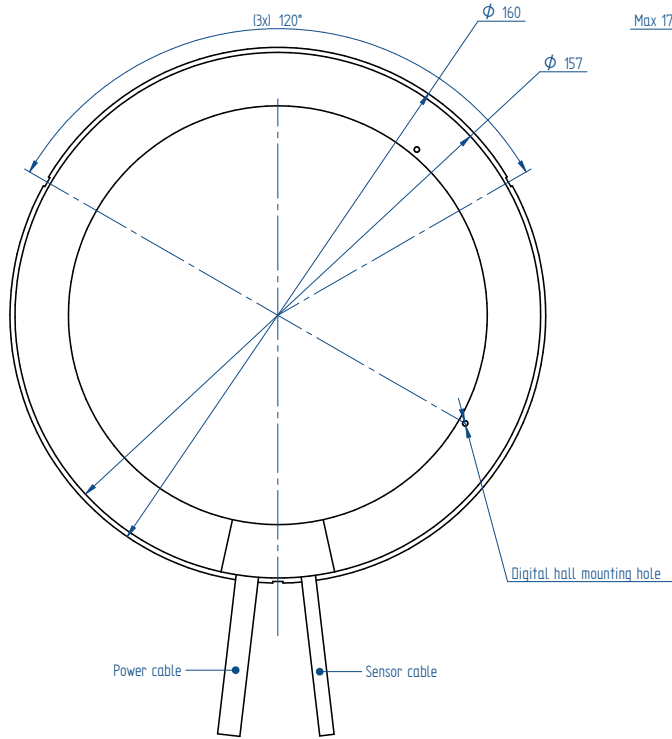

QTR-A 160-17

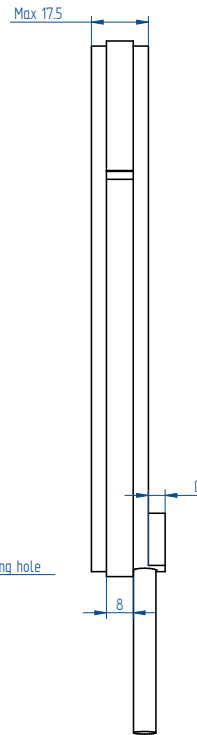

QTR-A 160-25

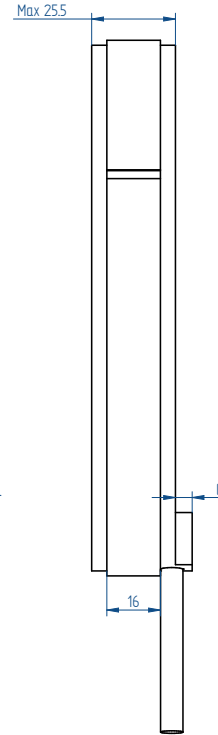

QTR-A 160-34

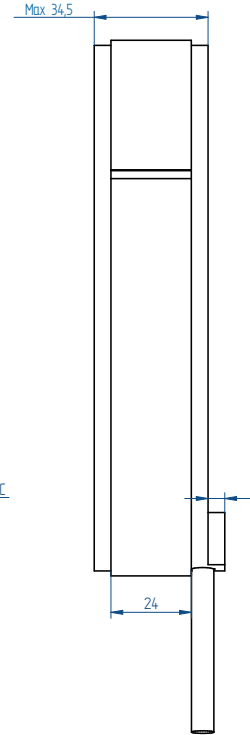

QTR-A 160-60

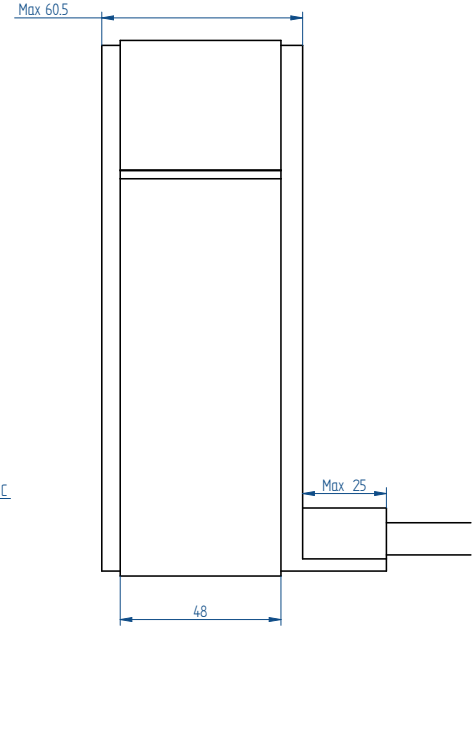

ROTOR

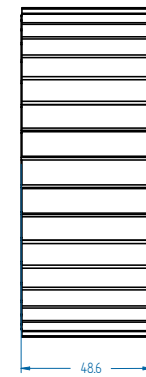
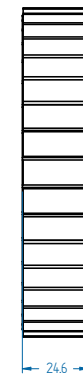
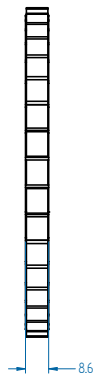
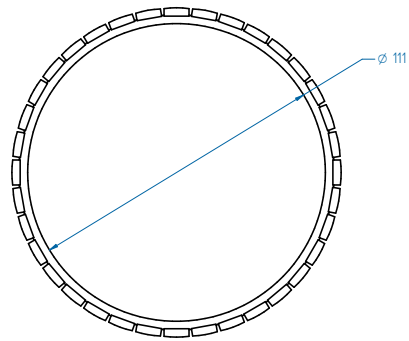

* All sizes are in mm

winding	C (mm)
N	3.5
Y+Z	5.5

©2019 Tecnotion BV - All rights reserved - The contents of this document are subject to change without prior notice.

	Parameter	Remarks	Symbol	Unit	QTR-A-160-17			QTR-A-160-25			QTR-A-160-34		QTR-A-160-60
					N	Y	Z	N	Y	Z	N	Z	N
Performance	Winding type				N	Y	Z	N	Y	Z	N	Z	N
	Motortype max. voltage ph-ph	3-phase synchronous		$V_{acrms} (V_{dc})$	230 (300)							420 (600)	
	Ultimate torque @ 20°C/s increase	magnet @ 25°C	T_u	Nm	9.3	10.6	10.6	19.6	22.4	22.4	34.1	33.6	91.6
	Peak torque @ 6°C/s increase	magnet @ 25°C	T_p	Nm	6.2	7.1	7.1	12.5	14.2	14.2	21.7	21.4	58.3
	Continuous torque	coil @ 100°C	T_c	Nm	4.1	4.2	4.2	9.4	9.7	9.7	15.7	15.0	36.3
	Maximum speed ⁽³⁾ @ 48 Volt	@ T_c	n_{max}	rpm	142	467	965	0	165	441	0	259	0
	Maximum speed @ max. voltage	@ T_c	n_{max}	rpm	2145	3871	6663	1084	2039	3604	555	2464	411
	Motor torque constant	up to I_c	K_t	Nm/A _{rms}	0.96	0.54	0.31	1.92	1.07	0.62	3.45	0.93	9.20
	Motor constant	coils @ 25°C	K_m	(Nm) ² /W	0.12	0.13	0.13	0.35	0.38	0.38	0.73	0.67	2.29
Electrical	Ultimate current	magnet @ 25°C	I_u	A _{rms}	13.8	28.2	48.8	13.8	28.2	48.8	13.3	48.8	13.5
	Peak current	magnet @ 25°C	I_p	A _{rms}	7.6	15.4	26.7	7.6	15.4	26.7	7.3	26.7	7.4
	Maximum continuous current ⁽¹⁾	coils @ 100°C	I_c	A _{rms}	4.3	7.8	13.4	4.9	9.0	15.7	4.6	16.2	3.9
	Back EMF phase-phase _{peak}		K_e	V/krpm	82	46	26	164	92	53	295	79	787
	Back EMF phase-phase _{rms}		K_e	V/krpm	58	32	19	116	65	37	209	56	556
	Coil resistance per phase	coils @ 25°C ex. cable	R	Ω	2.47	0.75	0.25	3.47	1.03	0.35	5.45	0.44	12.30
	Coil induction per phase	$l < 0.6 l_p$	L	mH	4.89	1.57	0.52	7.68	2.45	0.82	15.0	1.11	47.9
	Electrical time constant	coils @ 25°C	τ_e	ms	2.0	2.1	2.1	2.2	2.4	2.4	2.8	2.5	3.9
	Poles		N_{mgn}	nr	36	36	36	36	36	36	36	36	36
Thermal	Continuous power loss	coils @ 100°C	P_c	W	174	174	174	326	326	326	441	441	750
	Thermal resistance ⁽²⁾	coils to mount. sfc.	R_{th}	°C/W	0.43	0.43	0.43	0.23	0.23	0.23	0.17	0.17	0.10
	Thermal time constant	up to 63% max. coiltemp	τ_{th}	s	25	29	29	19	22	22	21	21	29
	Temperature cut-off / sensor				PTC 1kΩ / KTY83-122								
Mechanical	Stator OD		OD_s	mm	160								
	Rotor ID		ID_r	mm	111								
	Motor height		H_{motor}	mm	17			25			34		60
	Lamination stack height		H_{arm}	mm	8			16			24		48
	Rotor inertia		J_r	kg*m ²	4.7E-04			9.2E-04			1.4E-03		2.6E-03
	Stator mass	excluding cables	M_s	g	527			875			1212		2555
	Rotor mass		M_r	g	138			269			401		754
	Total mass	excluding cables	M_T	g	665			1144			1613		3309
	Cable mass	all cables	m	g	63	90	90	63	90	90	63	90	95
Cable type (power)	length 0.5 m	d	mm (AWG)	6.5 (20)	6.7 (14)	6.7 (14)	6.5 (20)	6.7 (14)	6.7 (14)	6.5 (20)	6.7 (14)	9.6 (18)	
Cable type (sensor)	length 0.5 m	d	mm (AWG)	4.3 (26)									



QTR-A-160 Stator and rotor shown with a height of 17 mm

- All specifications ±10%
- These values are only applicable when the mounting surface is at 20°C and the motor is driven at maximum continuous current. If these values differ in your application, please check our simulation tool or manual.
 - R_{th} based on radial mounting of stator lamination stack.
 - MAXIMUM allowable speed for QTR-A 160 series motors is 12,000 rpm. If you plan a high speed application, please contact Tecnotion.

Mounting instructions and tolerances can be found in the torque installation manual. Manuals and 3D CAD files can be downloaded from our website.

STATOR

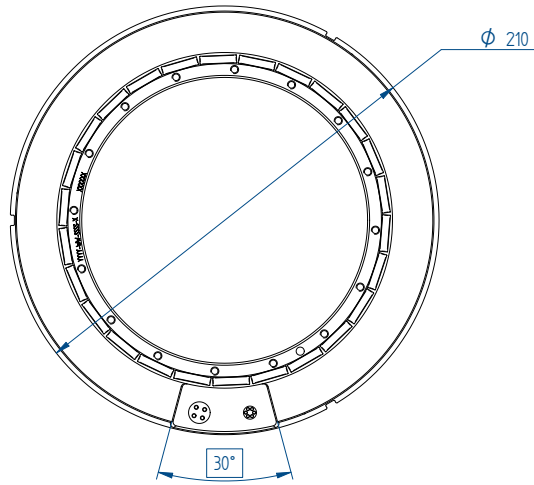

QTL-A 210-65

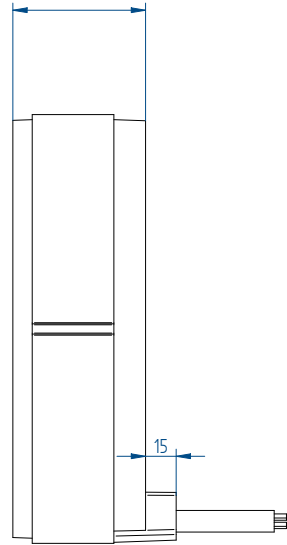

QTL-A 210-85

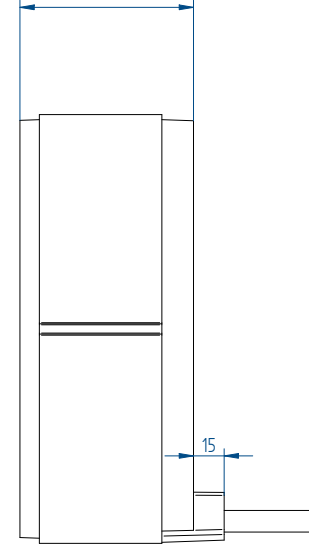

QTL-A 210-105

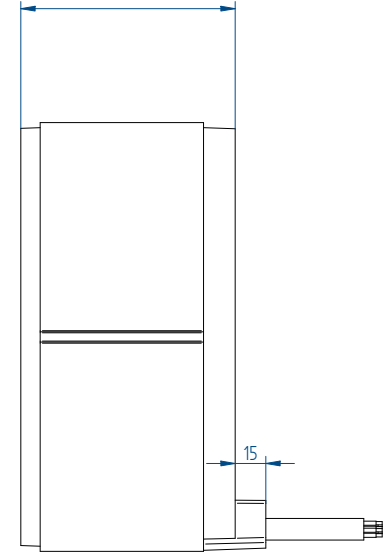

ROTOR

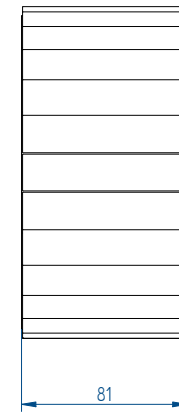
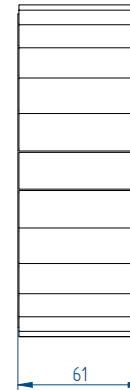
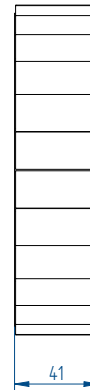
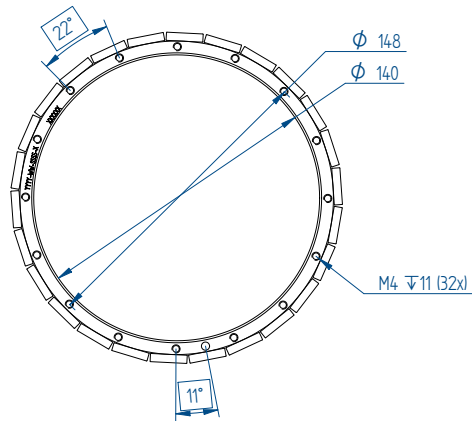

* All sizes are in mm

©2019 Tecnotion BV - All rights reserved - The contents of this document are subject to change without prior notice.



QTL 210 series, with a height of 65 mm

	Parameter	Remarks	Symbol	Unit	QTL-A 210-65	QTL-A 210-85	QTL-A 210-105
Performance	Winding type				N	N	N
	Motortype max. voltage ph-ph	3-phase synchronous		$V_{ac,rms} (V_{dc})$		480 (680)	
	Ultimate torque @ 20°C/s increase	magnet @ 25°C	T_u	Nm	173	259	346
	Peak torque @ 6°C/s increase	magnet @ 25°C	T_p	Nm	140	211	281
	Continuous torque	coil @ 100°C	T_c	Nm	65	103	142
	Stall torque	coil @ 100°C	T_s	Nm	46	73	100
	Maximum speed ⁽¹⁾	@Tc @ 680 Vdc	n_{max}	rpm	716	457	326
	Motor torque constant	up to Ic	K_t	Nm/A _{rms}	8.7	13.1	17.5
	Motor constant	coils @ 25°C	K_m	(Nm) ² /W	8.0	13.5	19.2
	Electrical	Ultimate current	magnet @ 25°C	I_u	A _{rms}	22.0	22.0
Peak current		magnet @ 25 °C	I_p	A _{rms}	16.9	16.9	16.9
Maximum continuous current ⁽²⁾		coils @ 100°C	I_c	A _{rms}	7.45	7.88	8.11
Stall Current ⁽²⁾		coils @ 100°C	I_s	A _{rms}	5.27	5.57	5.74
Back EMF phase-phase _{peak}			K_e	V/krpm	747	1121	1494
Back EMF phase-phase _{RMS}			K_e	V/krpm	528	793	1057
Coil resistance per phase		coils @ 25°C ex. cable	R	Ω	3.18	4.25	5.31
Coil induction per phase		I < 0.6 Ip	L	mH	16.0	22.3	28.7
Electrical time constant			τ_e	ms	5.0	5.3	5.4
Poles			N_{mgn}	nr	26	26	26
Thermal	Continuous power loss	coils @ 100°C	P_c	W	690	1028	1363
	Thermal resistance ⁽³⁾	coils to mount. sfc.	R_{th}	°C/W	0.116	0.078	0.059
	Thermal time constant		τ_{th}	s	53	47	45
	Temperature cut-off / sensor				PTC 1kΩ (3x) / PT1000 (3x)		
Mechanical	Stator OD		OD _s	mm	210		
	Rotor ID		ID _R	mm	140		
	Motor height		H _{motor}	mm	65	85	105
	Lamination stack height		H _{arm}	mm	40	60	80
	Rotor inertia		J _R	kg*m ²	0.009	0.014	0.019
	Stator mass	excluding cables	M _s	kg	4.2	5.9	7.5
	Rotor mass		M _R	kg	1.6	2.4	3.2
	Total mass	excluding cables	M _T	kg	5.8	8.3	10.7
	Cable mass	all cables	m	g	500		
	Cable type (power)	length 2 m	d	mm (AWG)	10.6 (13)		
Cable type (sensor)	length 2 m	d	mm (AWG)	6.4 (25)			

All specifications ±0.0%

1. Actual values depend on bus voltage. Please check the T/n diagram in our manual or online simulation tool.
2. These values are only applicable when the mounting surface is at 20°C and the motor is driven at maximum continuous current. If these values differ in your application, please check our simulation tool or manual.
3. R_{th} based on radial mounting of stator lamination stack.

Mounting instructions and tolerances can be found in the torque installation manual. Manuals and 3D CAD files can be downloaded from our website.

STATOR

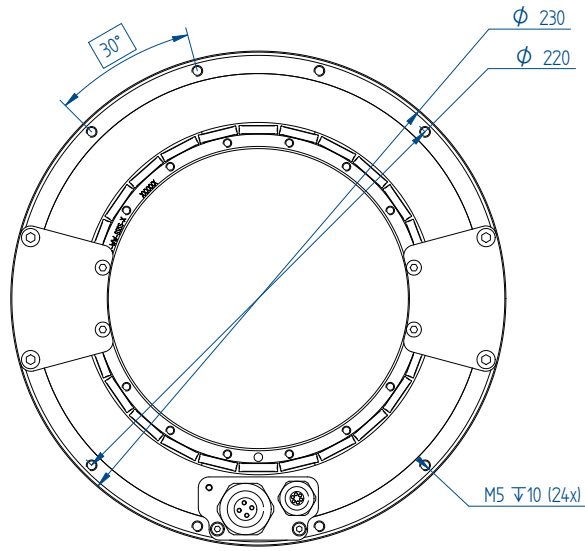

ROTOR

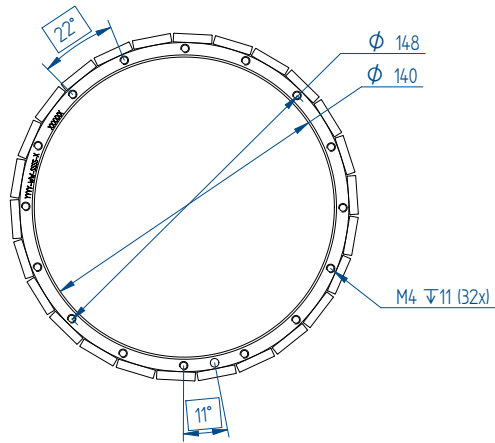

QTL-A 230-65

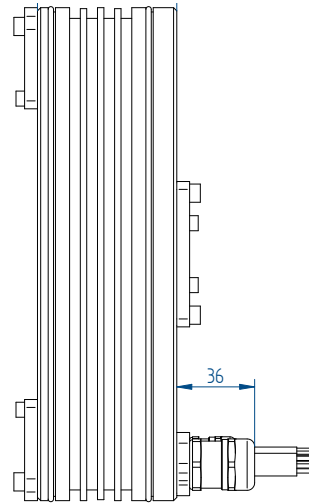

QTL-A 230-85

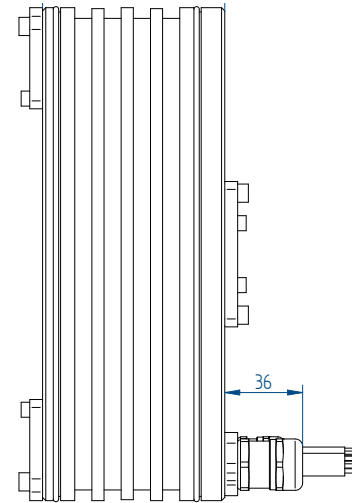

QTL-A 230-105

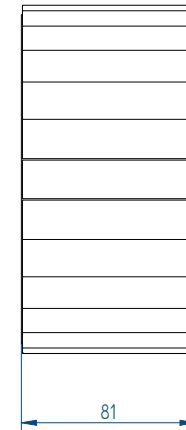
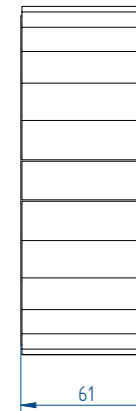
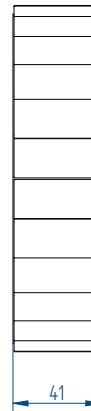
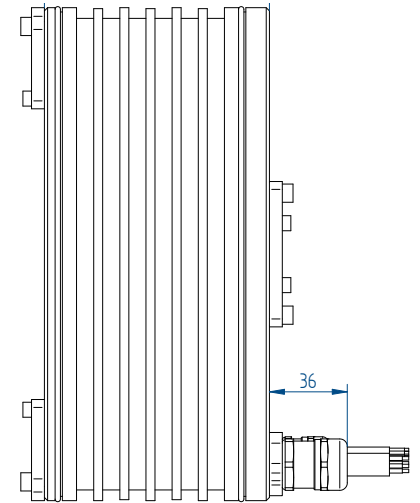

	Parameter	Remarks	Symbol	Unit	QTL-A 230-65	QTL-A 230-85	QTL-A 230-105
Performance	Winding type				N	N	N
	Motor type max. voltage ph-ph	3-phase synchronous		$V_{ac\ rms} (V_{dc})$	480 (680)		
	Ultimate torque @ 20°C/s increase	magnet @ 25°C	T_u	Nm	173	259	346
	Peak torque @ 6°C/s increase	magnet @ 25°C	T_p	Nm	140	211	281
	Continuous torque	coil @ 100°C	T_c	Nm	67	107	147
	Stall torque	coil @ 100°C	T_s	Nm	48	76	104
	Maximum speed ⁽¹⁾	@ T_c @ 680 Vdc	n_{max}	rpm	709	451	321
	Motor torque constant	up to I_c	K_t	Nm/A _{rms}	8.7	13.1	17.5
	Motor constant	coils @ 25°C	K_m	(Nm) ² /W	8.0	13.5	19.2
	Electrical	Ultimate current	magnet @ 25°C	I_u	A _{rms}	22.0	22.0
Peak current		magnet @ 25 °C	I_p	A _{rms}	16.9	16.9	16.9
Maximum continuous current ⁽²⁾		coils @ 100°C	I_c	A _{rms}	7.69	8.16	8.42
Stall current ⁽²⁾		coils @ 100°C	I_s	A _{rms}	5.44	5.77	5.95
Back EMF phase-phase _{peak}			K_e	V/krpm	747	1121	1494
Back EMF phase-phase _{RMS}			K_e	V/krpm	528	793	1057
Coil resistance per phase		coils @ 25°C ex. cable	R	Ω	3.18	4.25	5.31
Coil induction per phase		$l < 0.6 I_p$	L	mH	16.0	22.3	28.7
Electrical time constant			τ_e	ms	5.0	5.3	5.4
Poles			N_{mgn}	nr	26	26	26
Thermal	Continuous power loss	coils @ 100°C	P_c	W	735	1102	1469
	Thermal resistance ⁽³⁾	coils to mount. sfc.	R_{th}	°C/W	0.109	0.073	0.054
	Thermal time constant		τ_{th}	s	49	44	41
	Water cooling flow	for $\Delta T=3K$	Φ_w	l/min	3.5	5.3	7.0
	Water Cooling pressure drop	order of magnitude	ΔP_w	bar	0.7	1.0	1.5
	Temperature cut-off / sensor				PTC 1kΩ (3x) / PT1000 (3x)		
Mechanical	Stator OD		OD_s	mm	230		
	Rotor ID		ID_R	mm	140		
	Motor height		H_{motor}	mm	65	85	105
	Lamination stack height		H_{arm}	mm	40	60	80
	Rotor inertia		J_R	kg*m ²	0.009	0.014	0.019
	Stator mass	excluding cables	M_s	kg	5.2	7.2	9.0
	Rotor mass		M_R	kg	1.6	2.4	3.2
	Total mass	excluding cables	M_T	kg	6.8	9.6	12.2
	Cable mass	all cables	m	g	500		
	Cable type (power)	length 2 m	d	mm (AWG)	10.6 (13)		
Cable type (sensor)	length 2 m	d	mm (AWG)	6.4 (25)			



QTL 230 series, with a height of 85 mm

All specifications ±0%

1. Actual values depend on bus voltage. Please check the T/n diagram in our manual or online simulation tool.
2. These values are only applicable when the mounting surface is at 20°C and the motor is driven at maximum continuous current. If these values differ in your application, please check our simulation tool or manual.
3. R_{th} based on given water flow and pressure.

Mounting instructions and tolerances can be found in the torque installation manual. Manuals and 3D CAD files can be downloaded from our website.

STATOR

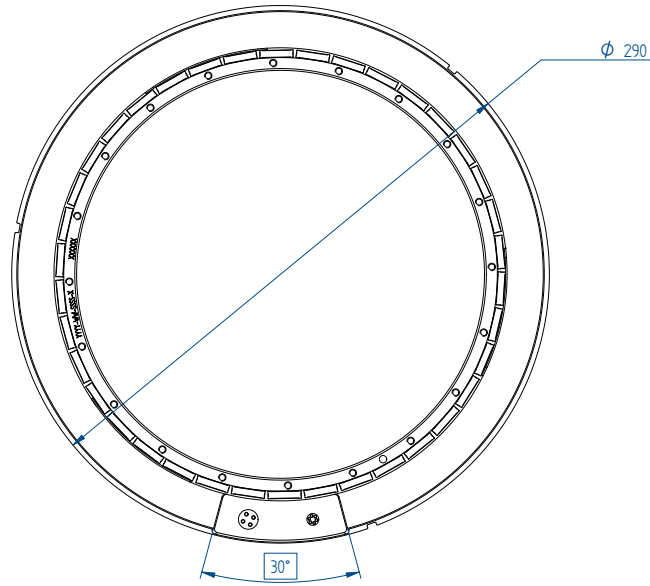

QTL-A 290-65

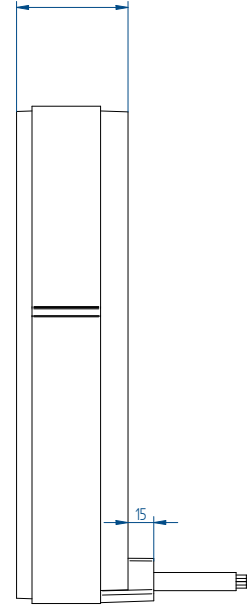

QTL-A 290-85

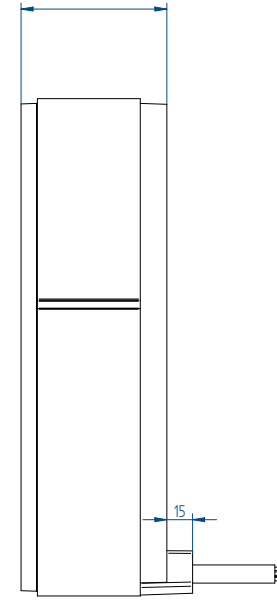

QTL-A 290-105

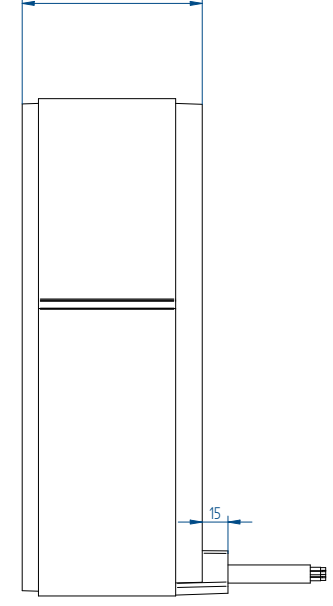

ROTOR

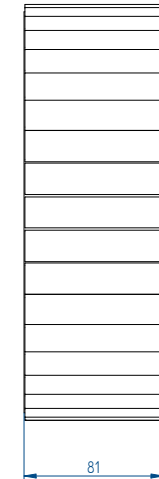
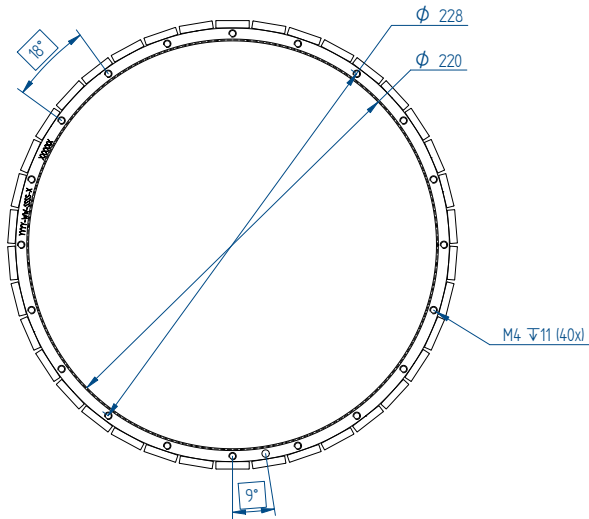

©2019 Tecnotion BV - All rights reserved - The contents of this document are subject to change without prior notice.



QTL 290 series, with a height of 65 mm

	Parameter	Remarks	Symbol	Unit	QTL-A 290-65	QTL-A 290-85	QTL-A 290-105
Performance	Winding type				N	N	N
	Motortype max. voltage ph-ph	3-phase synchronous		$V_{ac\ rms} (V_{dc})$		480 (680)	
	Ultimate torque @ 20°C/s increase	magnet @ 25°C	T_u	Nm	389	583	778
	Peak torque @ 6°C/s increase	magnet @ 25°C	T_p	Nm	316	474	632
	Continuous torque	coil @ 100°C	T_c	Nm	140	222	305
	Stall torque	coil @ 100°C	T_s	Nm	99	157	215
	Maximum speed ⁽¹⁾	@ Tc @ 680 Vdc	n_{max}	rpm	306	189	130
	Motor torque constant	up to Ic	K_t	Nm/A _{rms}	19.7	29.5	39.3
	Motor constant	coils @ 25°C	K_m	(Nm) ² /W	27.0	45.5	64.7
	Electrical	Ultimate current	magnet @ 25°C	I_u	A _{rms}	22.0	22.0
Peak current		magnet @ 25°C	I_p	A _{rms}	16.9	16.9	16.9
Maximum continuous current ⁽²⁾		coils @ 100°C	I_c	A _{rms}	7.14	7.54	7.75
Stall current ⁽²⁾		coils @ 100°C	I_s	A _{rms}	5.05	5.33	5.48
Back EMF phase-phase _{peak}			K_e	V/krpm	1681	2521	3362
Back EMF phase-phase _{RMS}			K_e	V/krpm	1189	1783	2377
Coil resistance per phase		coils @ 25°C ex. cable	R	Ω	4.77	6.37	7.96
Coil induction per phase		l < 0.6 lp	L	mH	23.9	34.7	45.5
Electrical time constant			τ_e	ms	5.0	5.5	5.7
Poles			N_{mgn}	nr	38	38	38
Thermal	Continuous power loss	coils @ 100°C	P_c	W	948	1410	1864
	Thermal resistance ⁽³⁾	coils to mount. sfc.	R_{th}	°C/W	0.084	0.057	0.043
	Thermal time constant		τ_{th}	s	57	52	49
	Temperature cut-off / sensor				PTC 1kΩ (3x) / PT1000 (3x)		
Mechanical	Stator OD		OD _s	mm	290		
	Rotor ID		ID _R	mm	220		
	Motor height		H _{motor}	mm	65	85	105
	Lamination stack height		H _{arm}	mm	40	60	80
	Rotor inertia		J _R	kg*m ²	0.031	0.046	0.061
	Stator mass	excluding cables	M _s	kg	6.0	8.3	10.8
	Rotor mass		M _R	kg	2.3	3.5	4.7
	Total mass	excluding cables	M _T	kg	8.3	11.8	15.5
	Cable mass	all cables	m	g	500		
	Cable type (power)	length 2 m	d	mm (AWG)	10.6 (13)		
Cable type (sensor)	length 2 m	d	mm (AWG)	6.4 (25)			

All specifications ±0%

1. Actual values depend on bus voltage. Please check the T/n diagram in our manual or online simulation tool.
2. These values are only applicable when the mounting surface is at 20°C and the motor is driven at maximum continuous current. If these values differ in your application, please check our simulation tool or manual.
3. R_{th} based on radial mounting of stator lamination stack.

Mounting instructions and tolerances can be found in the torque installation manual. Manuals and 3D CAD files can be downloaded from our website.

STATOR

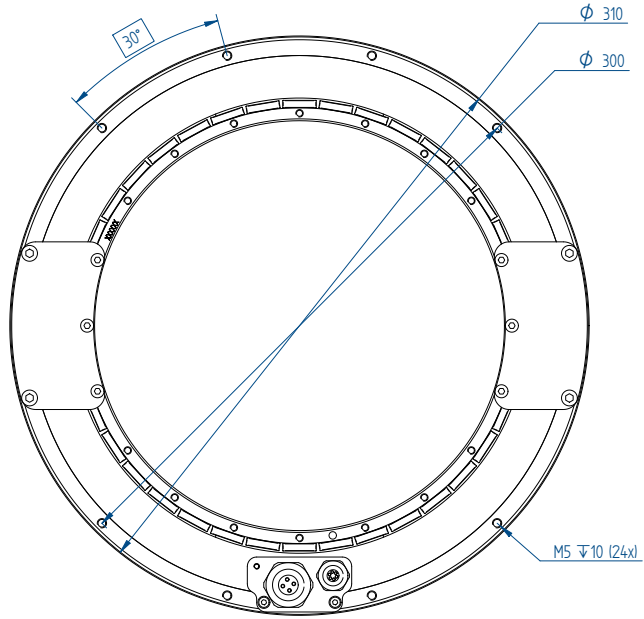

ROTOR

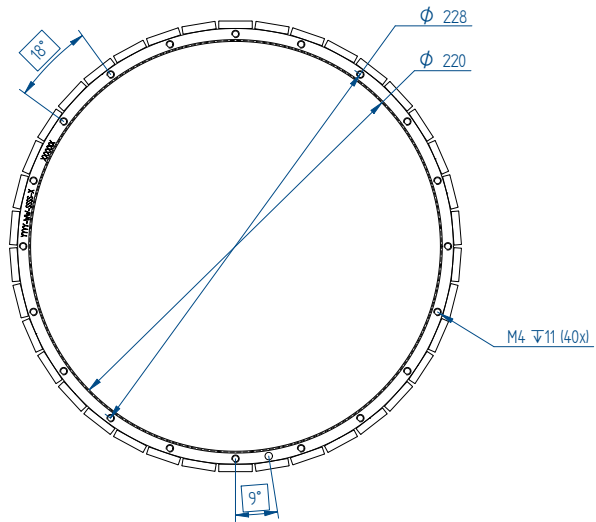

QTL-A 310-65

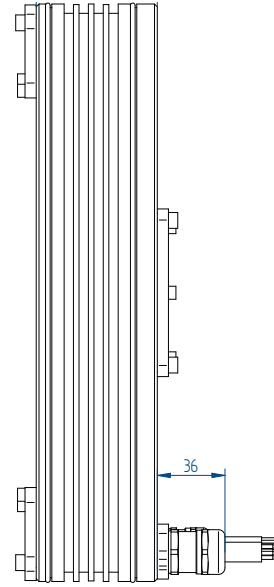

QTL-A 310-85

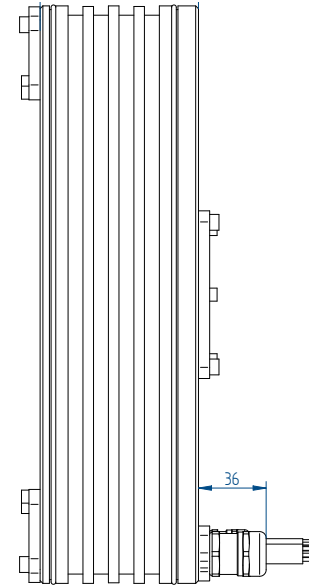

QTL-A 310-105

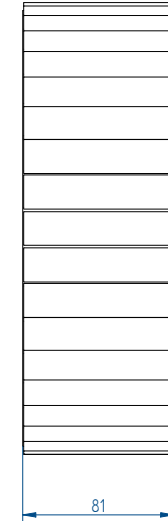
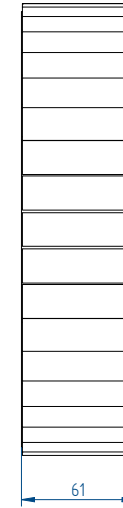
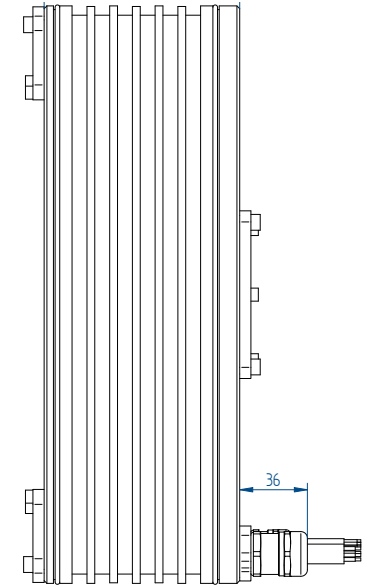

©2019 Tecnotion BV - All rights reserved - The contents of this document are subject to change without prior notice.

	Parameter	Remarks	Symbol	Unit	QTL-A 310-65	QTL-A 310-85	QTL-A 310-105
Performance	Winding type				N	N	N
	Motor type max. voltage ph-ph	3-phase synchronous		$V_{ac\ rms} (V_{dc})$	480 (680)		
	Ultimate torque @ 20°C/s increase	magnet @ 25°C	T_u	Nm	389	583	778
	Peak torque @ 6°C/s increase	magnet @ 25°C	T_p	Nm	316	474	632
	Continuous torque	coil @ 100°C	T_c	Nm	151	241	331
	Stall torque	coil @ 100°C	T_s	Nm	107	170	234
	Maximum speed ⁽¹⁾	@ T_c @ 680 Vdc	n_{max}	rpm	298	182	124
	Motor torque constant	up to I_c	K_t	Nm/A _{rms}	19.7	29.5	39.3
	Motor constant	coils @ 25°C	K_m	(Nm) ² /W	27.0	45.5	64.7
	Electrical	Ultimate current	magnet @ 25°C	I_u	A _{rms}	22.0	22.0
Peak current		magnet @ 25°C	I_p	A _{rms}	16.9	16.9	16.9
Maximum continuous current ⁽²⁾		coils @ 100°C	I_c	A _{rms}	7.70	8.16	8.42
Stall current ⁽²⁾		coils @ 100°C	I_s	A _{rms}	5.44	5.77	5.96
Back EMF phase-phase _{peak}			K_e	V/krpm	1681	2521	3362
Back EMF phase-phase _{RMS}			K_e	V/krpm	1189	1783	2377
Coil resistance per phase		coils @ 25°C ex. cable	R	Ω	4.77	6.37	7.96
Coil induction per phase		$l < 0.6 l_p$	L	mH	23.9	34.7	45.5
Electrical time constant			τ_e	ms	5.0	5.5	5.7
Poles			N_{mgn}	nr	38	38	38
Thermal	Continuous power loss	coils @ 100°C	P_c	W	1102	1653	2204
	Thermal resistance ⁽³⁾	coils to mount. sfc.	R_{th}	°C/W	0.073	0.048	0.036
	Thermal time constant		τ_{th}	s	49	44	41
	Water cooling flow	for $\Delta T=3K$	Φ_w	l/min	5.3	7.9	10.5
	Water cooling pressure drop	order of magnitude	ΔP_w	bar	1.0	1.4	2.0
	Temperature cut-off / sensor				PTC 1kΩ (3x) / PT1000 (3x)		
Mechanical	Stator OD		OD_s	mm	310		
	Rotor ID		ID_R	mm	220		
	Motor height		H_{motor}	mm	65	85	105
	Lamination stack height		H_{arm}	mm	40	60	80
	Rotor inertia		J_R	kg*m ²	0.031	0.046	0.061
	Stator mass	excluding cables	M_s	kg	7.4	10.1	12.9
	Rotor mass		M_R	kg	2.3	3.5	4.7
	Total mass	excluding cables	M_T	kg	9.7	13.6	17.6
	Cable mass	all cables	m	g	500		
	Cable type (power)	length 2 m	d	mm (AWG)	10.6 (13)		
Cable type (sensor)	length 2 m	d	mm (AWG)	6.4 (25)			



QTL 310 series, with a height of 85 mm

All specifications ±0%

1. Actual values depend on bus voltage. Please check the T/n diagram in our manual or online simulation tool.
2. These values are only applicable when the mounting surface is at 20°C and the motor is driven at maximum continuous current. If these values differ in your application, please check our simulation tool or manual.
3. R_{th} based on given water flow and pressure.

Additional products

To download our CAD files, installation manuals, product specifications and more, visit our website at:

www.tecnotion.com



Product series

Iron core & ironless motor series

Tecnotion's linear motor series rely on 30 years of linear motor development experience. All motors excel in their force density ratings. They offer continuous force in a range of 10 Newton to 3000 Newton in a surprisingly small package.

Tecnotion can provide linear solutions for most applications which require a strong iron core linear motor or a highly dynamic ironless type linear motor.



Vacuum series

Outgassing down to 10^{-8} mbar

Many years of experience is used in designing and building vacuum coils and magnets. Tecnotion can supply any vacuum linear motor that can match even the strictest vacuum requirements, for instance in the semiconductor industry.

Our vacuum rated ironless linear motors are a specifically designed coil units and magnet yokes for use in high vacuum, down to 10^{-8} mBar.

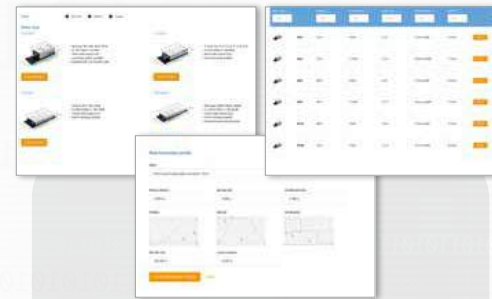

Simulation tool

Analyze your application

Save precious time by using our FREE online motor simulation tool. Our specialized software helps you find the best motor for the application and generate reports within seconds, without having to make time consuming calculations by hand.

The tool will provide you with diagrams for position, velocity, acceleration, jerk, torque, power, voltage, current, temperature, torque vs. velocity and more. Find the simulation tool at www.tecnotion.com/simtool.



Custom motors

Motor solutions

Besides the standard catalogue items we offer custom linear motor solutions. Some examples: custom windings, cable confection and vacuum motors for transport and positioning in vacuum.

Besides this Tecnotion offers moving magnet motors and linear solutions, completely designed toward your needs. For more information please contact Tecnotion.

Article numbers

Series	Article	Article code
QTR	TORQUE KIT QTR-A-65-17 N	10 8062
QTR	TORQUE KIT QTR-A-65-25 N	10 8393
QTR	TORQUE KIT QTR-A-65-34 Y	10 8394
QTR	TORQUE KIT QTR-A-65-60 Y	10 8395
QTR	TORQUE KIT QTR-A-78-17 N	10 8397
QTR	TORQUE KIT QTR-A-78-25 Y	10 8399
QTR	TORQUE KIT QTR-A-78-34 Y	10 8400
QTR	TORQUE KIT QTR-A-78-60 Y	10 8401
QTR	TORQUE KIT QTR-A-105-17-N	4022 368 6120
QTR	TORQUE KIT QTR-A-105-17-Y	10 8848
QTR	TORQUE KIT QTR-A-105-17-Z	10 8158
QTR	TORQUE KIT QTR-A-105-25-N	4022 368 6121
QTR	TORQUE KIT QTR-A-105-25-Y	10 9393
QTR	TORQUE KIT QTR-A-105-25-Z	10 9398
QTR	TORQUE KIT QTR-A-105-34-N	4022 368 6122
QTR	TORQUE KIT QTR-A-105-34-Y	10 9394
QTR	TORQUE KIT QTR-A-105-34-Z	10 9399
QTR	TORQUE KIT QTR-A-105-60-N	4022 368 6123
QTR	TORQUE KIT QTR-A-133-17-N	4022 368 6140
QTR	TORQUE KIT QTR-A-133-17-Y	10 9395
QTR	TORQUE KIT QTR-A-133-17-Z	10 9400
QTR	TORQUE KIT QTR-A-133-25-N	4022 368 6141
QTR	TORQUE KIT QTR-A-133-25-Y	109396
QTR	TORQUE KIT QTR-A-133-25-Z	10 8159
QTR	TORQUE KIT QTR-A-133-34-N	4022 368 6142
QTR	TORQUE KIT QTR-A-133-34-Z	10 9401
QTR	TORQUE KIT QTR-A-133-60-N	4022 368 6143
QTR	TORQUE KIT QTR-A-160-17-N	4022 368 6160
QTR	TORQUE KIT QTR-A-160-17-Y	10 7771
QTR	TORQUE KIT QTR-A-160-17-Z	10 9402

Series	Article	Article code
QTR	TORQUE KIT QTR-A-160-25-N	4022 368 6161
QTR	TORQUE KIT QTR-A-160-25-Y	10 9397
QTR	TORQUE KIT QTR-A-160-25-Z	10 9403
QTR	TORQUE KIT QTR-A-160-34-N	4022 368 6162
QTR	TORQUE KIT QTR-A-160-34-Z	10 8160
QTR	TORQUE KIT QTR-A-160-60-N	4022 368 6163
QTR	DIGITAL HALL MODULE QTR 65	10 8781
QTR	DIGITAL HALL MODULE QTR 78	10 8782
QTR	DIGITAL HALL MODULE QTR 105	10 8233
QTR	DIGITAL HALL MODULE QTR 133	10 8234
QTR	DIGITAL HALL MODULE QTR 160	10 8235
QTL	TORQUE KIT QTL-A-210-65-N	11 1171
QTL	TORQUE KIT QTL-A-210-85-N	11 1173
QTL	TORQUE KIT QTL-A-210-105-N	11 1175
QTL	TORQUE KIT QTL-A-230-65-N	11 1127
QTL	TORQUE KIT QTL-A-230-85-N	11 1145
QTL	TORQUE KIT QTL-A-230-105-N	11 1153
QTL	TORQUE KIT QTL-A-290-65-N	11 1177
QTL	TORQUE KIT QTL-A-290-85-N	11 1180
QTL	TORQUE KIT QTL-A-290-105-N	11 1182
QTL	TORQUE KIT QTL-A-310-65-N	11 1078
QTL	TORQUE KIT QTL-A-310-85-N	11 1061
QTL	TORQUE KIT QTL-A-310-105-N	11 1100

This catalogue is offered to you by:

Tecnotion Headquarters

Twentepoort West 15
7609 RD Almelo
The Netherlands

Tel. +31 (0)546 536 300
Fax +31 (0)546 536 380
sales@tecnotion.com

Tecnotion GmbH

Elsenheimerstraße 59
80687 München
Deutschland

Tel. +49 89 381537-400
Fax +49 89 381537-409
info@tecnotion.de

Tecnotion Sp. z o.o.

Ul. Ryżowa 49
02-495 Warszawa
Poland

Tel. +48 606 544 046
info@tecnotion.pl

Tecnotion Rep. of Korea

Room #409,
Seoul Forest Halla Eco Valley
25, Ttukseom-ro 1-gil
04778 Seongdong-gu,
Seoul South Korea

Tel. +82 (0)10 4540 5599
korea@tecnotion.com

Tecnotion USA

200 Broad Hollow Rd -
Suite 207
Melville, NY, 11747
United States

Tel.+01 (631) 983-2833
sales@tecnotion.com